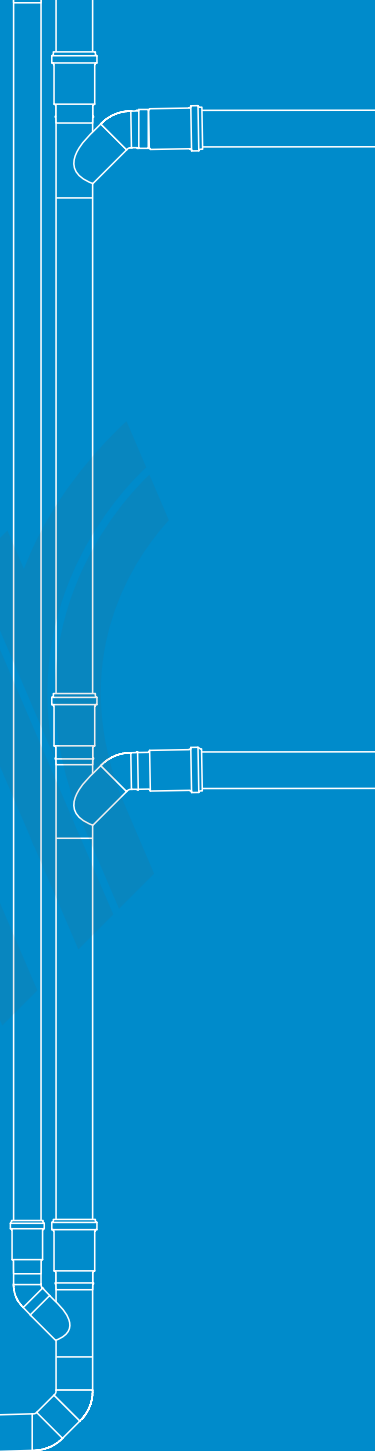


# THE TECHNICAL MANUAL FOR WASTE SYSTEMS

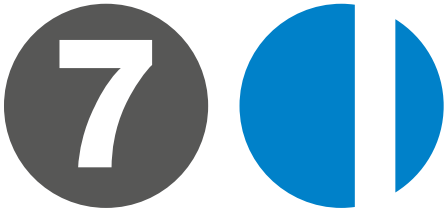
Characteristics, project design,  
calculation, installation and testing



## 7 System installation



**valsir**<sup>®</sup>  
QUALITY FOR PLUMBING



---

# SYSTEM INSTALLATION

valsir

## 7.1 Installation

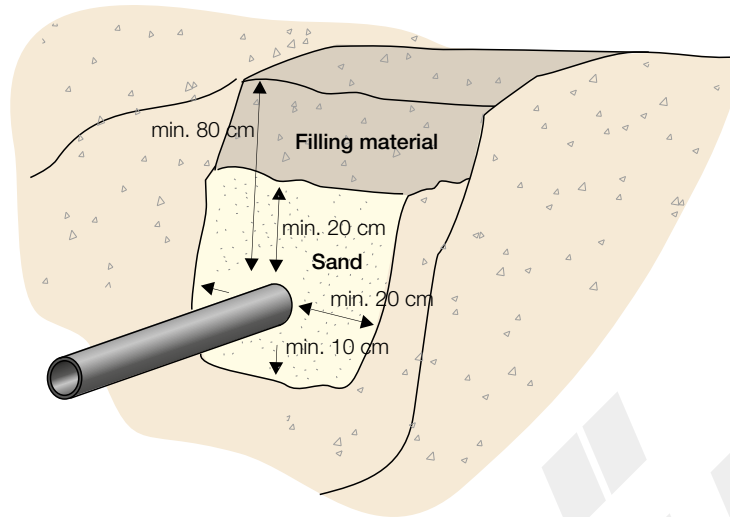
The indications given in this chapter are not intended to replace the provisions of standards or local regulations, which must prevail when choosing and adopting a specific installation criterion.

### 7.1.1 Underground installation

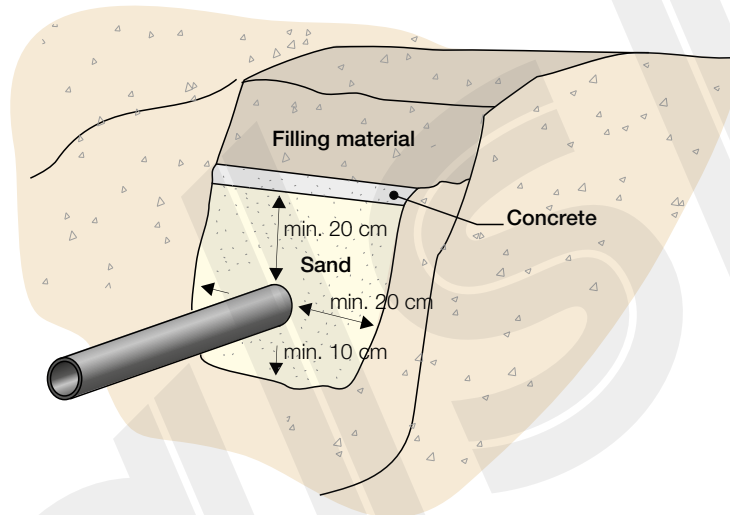
The Valsir® HDPE pipes fall into the BD application category and can therefore also be used for underground drainage applications under the footprint of the building. Local standards and regulations must be referred to regarding the possibility of underground installation and relative requirements. In any case, it is also recommended to take the following rules into consideration:

- The underground pipes must be laid at a distance of at least 1 m from any drinking water supply pipes and they must be positioned below the same.
- In the event of two or more pipes in the same trench, contact between them must be avoided; it is therefore recommended to leave a space of 10 to 15 cm between the pipes.
- The floor of the trench must be perfectly flat and must be free of stones, rocks or rubble.
- Before laying the pipe a 10 cm bedding of sand or strained clay must be prepared on the floor of the trench.
- Once the pipe has been laid, the same material (sand or strained clay) should be used to fill the trench to a height of 15 to 20 cm above the upper side of the pipe. This layer must be suitably pressed to prevent any possible movement of the underground pipe. It is important that the sand is pressed and the trench is filled immediately after the pipe has been laid: any subsiding, where the ground is permeable and has not been pressed, could in fact uncover the pipe.
- The minimum height of filling from the upper side of the pipe must be 80 cm (Figure 7.1). If the site is to be used by heavy machinery then it is recommended to cover the trench with lean concrete after it has been filled with sand, for a more even load distribution (Figure 7.2) or else to create a trench where the pipe is completely embedded in concrete (Figure 7.3); for greater detail on embedding in concrete see the following chapter.
- In underground installations thermal fluctuations are limited and hence smaller length variations need to be accounted for; for this reason longer sections of pipe can be connected without necessarily having to insert an expansion socket every 6 meters. When using expansion sockets on underground pipes the insertion indications (0 to 20) found on the outer surface of the socket do not need to be followed; it is recommended to insert the pipe to maximum socket depth, mark it, and then pull back 40 mm (Figure 7.4). **If the pipe is to be embedded completely in concrete do not use expansion sockets.**
- It is recommended to fill the pipe with water when the concrete is being poured. In this way it will be possible to identify any leaks caused by the filling operation and due to the fact that the solidification phase generates increases in temperature that can temporarily reduce the mechanical resistance of the pipe.

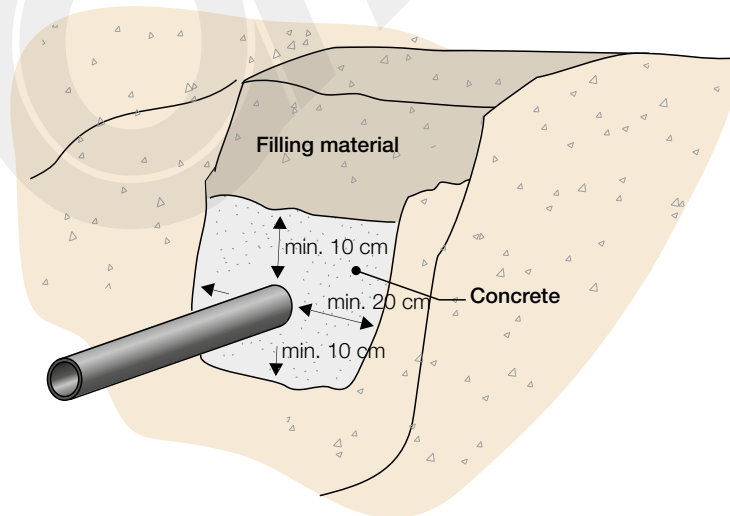
**Figure 7.1** Laying of pipe in the trench, transit of light loads.



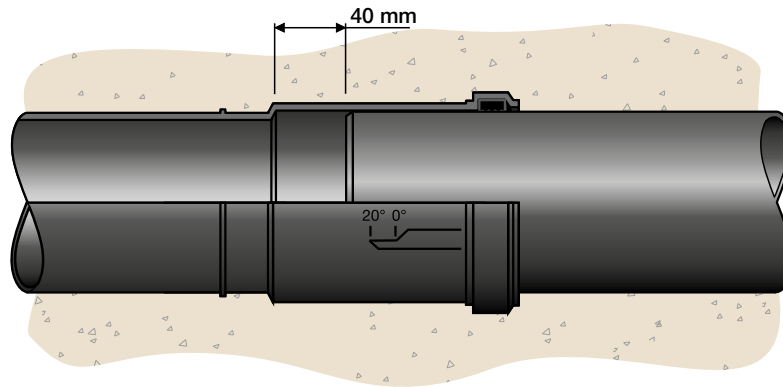
**Figure 7.2** Laying of pipe in the trench, transit of heavy loads.



**Figure 7.3** Laying of pipe in the trench with rigid solution.



**Figure 7.4** Application of expansion socket on underground pipe.



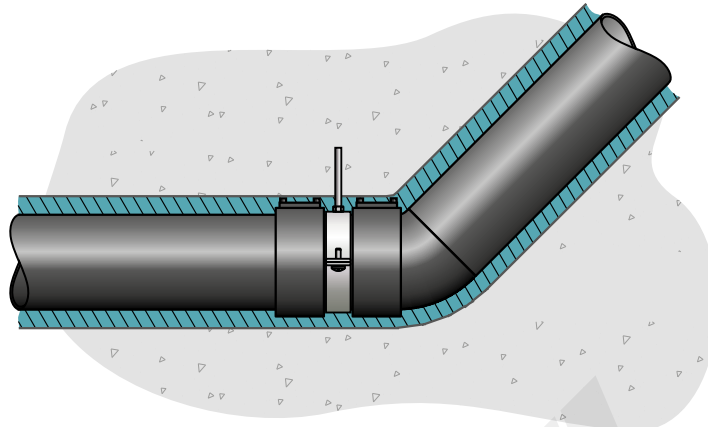
### 7.1.2 Embedding in concrete

Valsir waste pipes can be installed directly in concrete; it is common practice in some countries, for example, to install the waste branches of bathrooms and kitchens directly in the concrete slab.

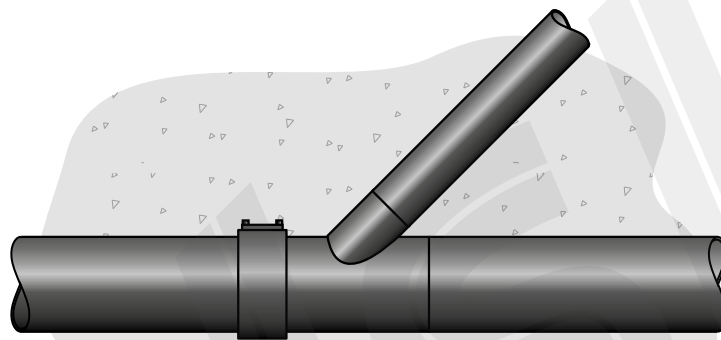
Unlike metal pipes, the forces that are generated in the pipe wall due to thermal fluctuations are completely absorbed by the plastic material thanks to its high elasticity. When embedding pipes in concrete, however, the following rules should be kept in consideration; these rules may vary for polyethylene pipes and polypropylene based pipes:

- In the case of a Valsir® HDPE waste system with thermal or acoustic insulation, the branches and bends must be protected from shearing forces caused by slippage inside the concrete. An anchor bracket should therefore be used between two electrofusion sleeves. The bracket must be equipped with a threaded rod to guarantee an adequate anchor point (Figure 7.5).
- In the case of a Valsir® HDPE waste system without thermal or acoustic insulation, the small branch diameters connected to large pipe diameters must be protected from shearing forces. It is therefore advisable to install an electrofusion coupling (Figure 7.6) or collar bush (Figure 7.7) near the branch.
- In the case of a Valsir® HDPE pipe without thermal or acoustic insulation and with a ring seal socket, a collar bush or electrofusion coupling must be installed when the length is greater than 2 m (Figure 7.8). The area between the socket and pipe must be covered with paper, plastic film or insulating tape to avoid the entrance of concrete (Figure 7.9).
- In the case of a Valsir® PP/PP3, Triplus® or Silere® waste system, which all have low heat expansion coefficients, the push-fit sockets alone are sufficient to generate a suitable fixed anchor point inside the concrete. No special precautions are necessary except to cover the area between the pipe and socket with paper, plastic film or insulating tape to avoid the entrance of concrete (Figure 7.9).
- It is recommended to always anchor the waste system to avoid movements during pouring of the cement that could lead to separation of the pipes or fittings from the sockets.
- The pipes that penetrate through building perimeter walls can be subject to considerable forces caused by the movement and settlement of the ground, in such cases the pipes should be covered with an insulating lagging.

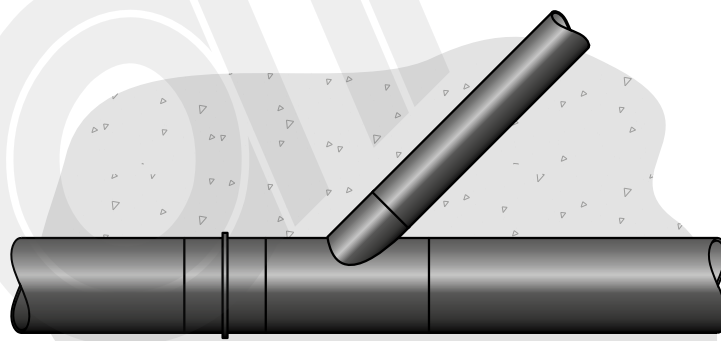
**Figure 7.5** Laying in concrete of Valsir® HDPE pipe with lagging.



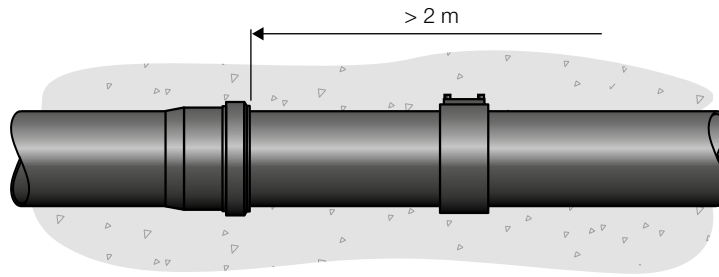
**Figure 7.6** Laying in concrete of Valsir® HDPE pipe, electrofusion coupling as fixed point.



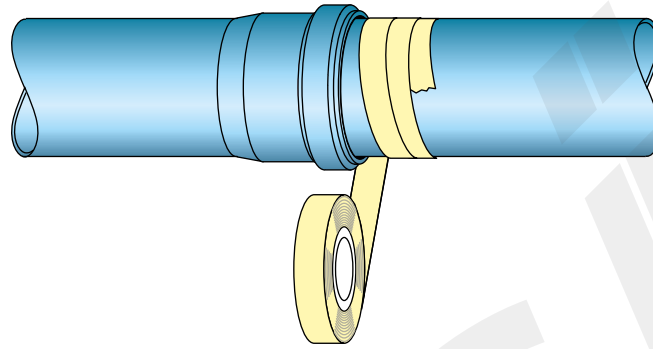
**Figure 7.7** Laying in concrete of Valsir® HDPE pipe, collar bush as fixed point.



**Figure 7.8** Laying in concrete of Valsir® HDPE pipe, push-fit ring seal socket.



**Figure 7.9** Laying in concrete, protection of push-fit ring seal socket.

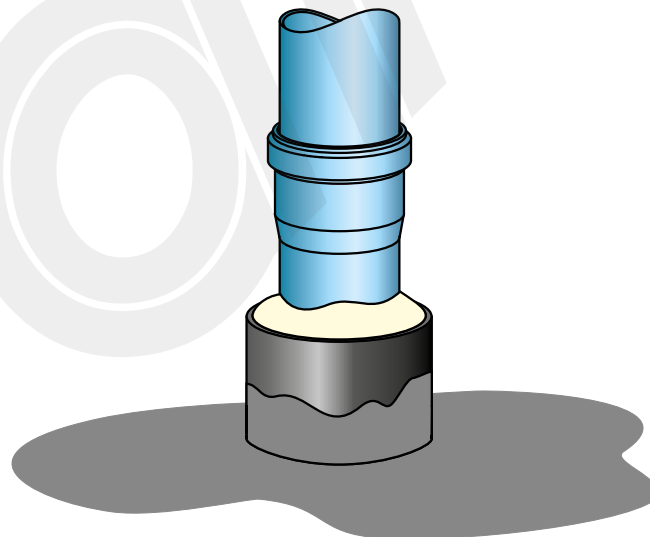


### 7.1.3 Passage through slabs

Whenever the pipes pass through slabs and protection against humidity is required with the use of tar or bituminous sheaths, careful attention must be paid in order to avoid damaging the pipes.

It is therefore recommended to fit the pipe inside a protective tube (protective lining) and to fill the space between them with insulating foam. The bituminous sheath or tar will be applied to the protective tube thus avoiding direct contact with the waste pipe.

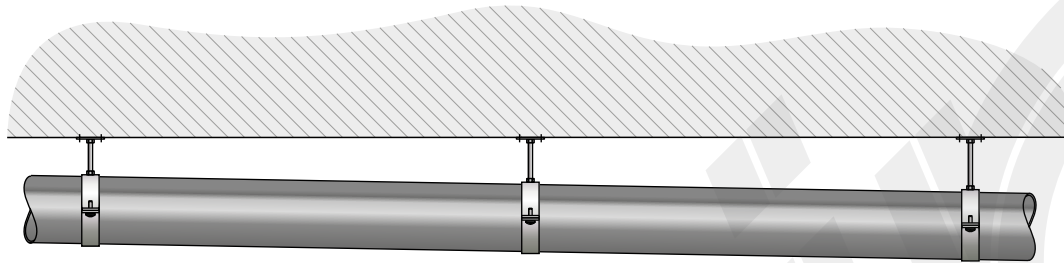
**Figure 7.10** Passage through slabs.



## 7.1.4 Exposed installation

In exposed installation, pipe supports must be used (sliding brackets or anchor brackets) to permanently fix the pipes to the building structure in order to support the weight of the pipes and relative components connected to them and the forces generated caused by water hammer or the activation of valves. Any pipes that need to be insulated following installation must be installed leaving sufficient space between the pipe and the building structure such as to allow the correct application of the insulation. The rules for the application of supports and the various mounting techniques are defined in the section “Bracketing”.

**Figure 7.11** Installation of exposed installation pipes.



For exposed installation pipes it is useful to have an idea of the water temperature at which condensation formation commences on the external surface of the pipe. The formation of condensation on the surface of the pipes obviously depends on the characteristics of the waste system chosen and on the environmental conditions. The values indicated in the table specify the temperature at which condensation formation commences on the external surface of the pipe, considering that the pipes are full of water and obviously without thermal insulation.

**Table 7.1** Temperatures at which condensation formation commences.

System	Air temperature $T_a$ [°C]																								
	10					20					30					40					50				
	Relative humidity of air UR [%]																								
	50	60	70	80	90	50	60	70	80	90	50	60	70	80	90	50	60	70	80	90	50	60	70	80	90
Temperature of waste water $T_w$ [°C]																									
PP/PP3	≤0	≤2	≤5	≤7	≤8	≤9	≤12	≤14	≤16	≤18	≤18	≤21	≤24	≤26	≤28	≤27	≤30	≤33	≤36	≤38	≤36	≤40	≤43	≤45	≤48
Triplus®	≤0	≤2	≤5	≤7	≤8	≤9	≤12	≤14	≤16	≤18	≤18	≤21	≤24	≤26	≤28	≤27	≤30	≤33	≤36	≤38	≤36	≤40	≤43	≤45	≤48
Silere®	≤-1	≤2	≤4	≤6	≤8	≤8	≤11	≤14	≤16	≤18	≤17	≤21	≤23	≤26	≤28	≤27	≤30	≤33	≤36	≤38	≤36	≤39	≤42	≤45	≤48
HDPE	≤0	≤2	≤5	≤7	≤8	≤9	≤12	≤14	≤16	≤18	≤18	≤21	≤24	≤26	≤28	≤27	≤30	≤33	≤36	≤38	≤36	≤40	≤43	≤45	≤48

Note. The values were not obtained experimentally but are based on a recognised calculation process.

## 7.1.5 General rules of installation

The following is a list of general rules that should be followed for all of the abovementioned types of installation:

- The pipes must be installed at a certain distance from each other which leaves sufficient space to allow them to be removed or to allow the correct application of thermal insulation.
- The pipes must not be installed inside transformer cabinets, above electric control panels or any electrical devices whatsoever.
- In the case of passages through horizontal or vertical structures such as walls, ceilings and floors, the pipes must be protected with insulating sheaths (for greater details see chapter “Noise in waste systems”).
- During installation of the waste system a map of all the pipes and relative connections should be made. On completion of the system the map will constitute a representation of the system as installed “on site” and must be handed over to the owner of the building.
- Horizontal pipes must always be installed by ensuring a gradient of 1 to 5% in the direction of flow; a good compromise between hydraulic performance and reduced size consists of applying a gradient of 2% (it is recommended to verify the existence of specific indications dictated by local regulations and standards).

## 7.2 Bracketing

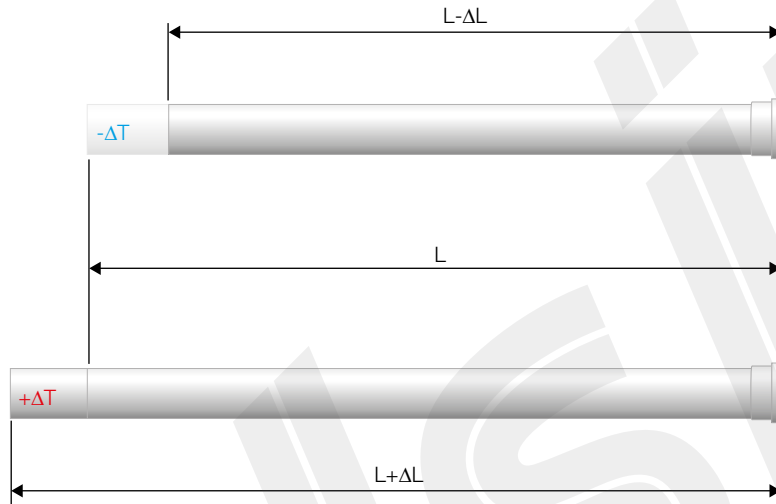
### 7.2.1 Preliminary considerations

All materials are subject to expansions or contractions caused by the increase or decrease in temperature. The variation in length  $\Delta L$  of a pipe of length  $L$  caused by a variation in temperature  $\Delta T$  between the temperature at which the pipe was installed and the current temperature is given by:

$$\Delta L = \alpha \cdot L \cdot \Delta T \quad [7.1]$$

where  $\alpha$  is the coefficient of linear heat expansion of the material. The following figure can be used to calculate the expansion or contraction of a pipe in relation to the difference in temperature to which it is subjected.

**Figure 7.12** Contraction and expansion of a waste pipe.



The prevention of such a variation in length in the material would generate a tensile stress (with  $\Delta T < 0$ ) or a compression stress (with  $\Delta T > 0$ ) given by:

$$\sigma = -E \cdot \alpha \cdot \Delta T \quad [7.2]$$

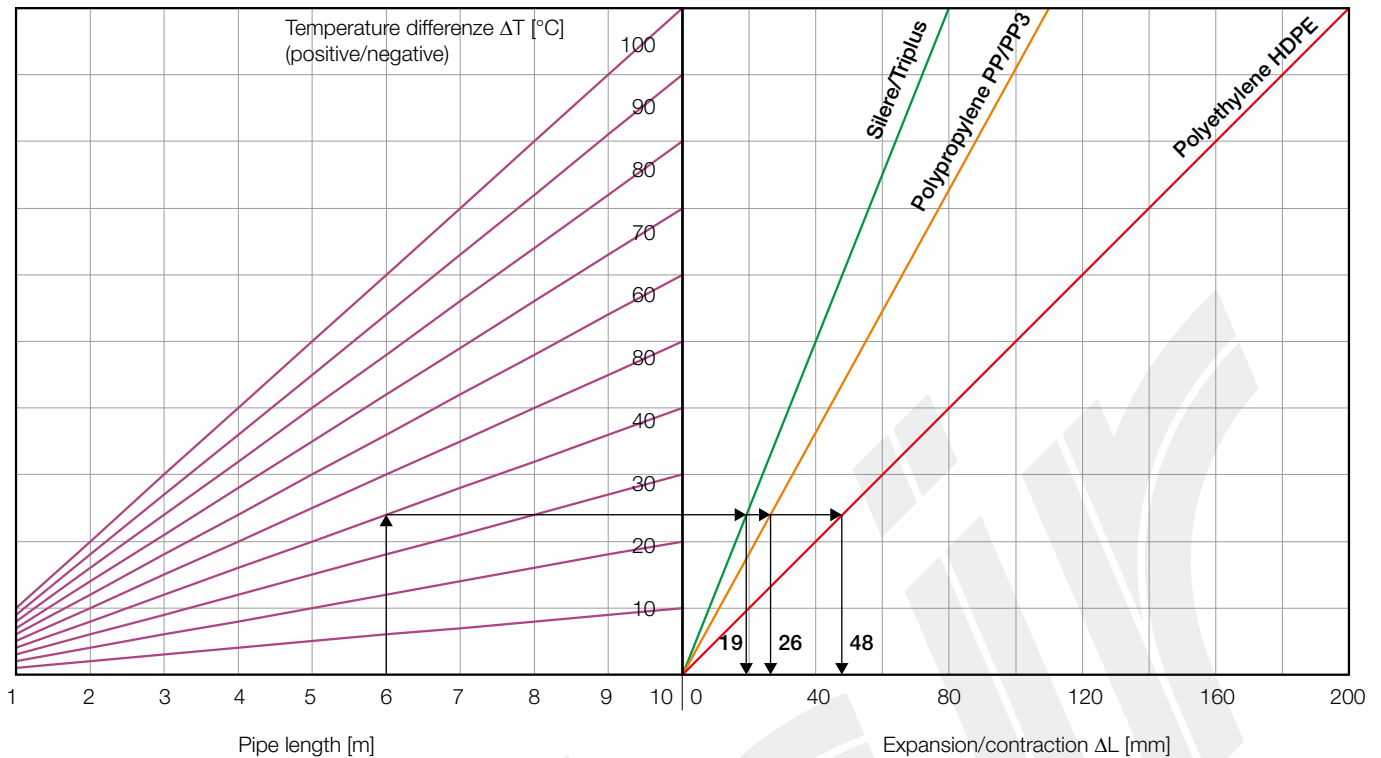
where  $E$  is the modulus of elasticity of the material.

When calculating expansions or contractions, the difference between the temperature at which the pipe was (or will be) installed and the maximum/minimum temperature expected when the system is operating, must always be taken into consideration.

**Table 7.2** Characteristics of some materials.

Pipe	Coefficient of linear heat expansion $\alpha$ [mm/m·°C]	Modulus of elasticity $E$ [MPa]	$E \cdot \alpha$ [MPa/°C]
Cast iron	0.010	105000	1.05
Steel	0.012	206000	2.47
Silere®	0.080	2800	0.22
Triplus®	0.080	1500	0.12
Polypropylene PP/PP3	0.110	1300	0.14
Polyethylene HDPE	0.200	1000	0.20

**Figure 7.13** Heat expansion/contraction of pipes.



The effects of heat expansion and contraction of plastic materials influence the methods of installation of waste systems that require different rules according to the type of installation in question (refer to the following sections for greater detail).

**Example 1.**

Calculate the linear heat expansion of a 6 m long polyethylene pipe that is installed at a temperature of 15°C and is subjected to a maximum operating temperature of 55°C.

By using the formula given previously we have

$$\Delta L = \alpha \cdot L \cdot \Delta T = 0.2 \cdot 6 \cdot (55 - 15) = 48 \text{ mm} \quad [7.3]$$

The same result can be obtained from the diagram in Figure 7.13. If the pipe used were Silere® then the expansion would be more than halved.

$$\Delta L = \alpha \cdot L \cdot \Delta T = 0.08 \cdot 6 \cdot (55 - 15) = 19 \text{ mm} \quad [7.4]$$

**Example 2.**

If the same pipe in the previous example were subject to an operating temperature of -10°C, what would the maximum contraction be?

$$\Delta L = \alpha \cdot L \cdot \Delta T = 0.2 \cdot 6 \cdot (-10 - 15) = -30 \text{ mm} \quad [7.5]$$

and for Silere® the result would be

$$\Delta L = \alpha \cdot L \cdot \Delta T = 0.08 \cdot 6 \cdot (-10 - 15) = -12 \text{ mm} \quad [7.6]$$

## 7.2.2 Types of bracketing

According to the system requirements and constraints, the following types of bracketing can be used for exposed installation pipes:

- Bracketing with expansion socket.
- Bracketing with push-fit socket.
- Bracketing with expansion compensation.
- Rigid bracketing.

Exposed installation of pipes requires the use of suitable brackets that must withstand the weight of the pipe, the weight of the waste water and the forces that are generated by expansion and contraction. In relation to the type of bracketing chosen, the so-called guide points and fixed points must be calculated, the rules of use of the same are dealt with in the following sections.

In all cases, if the waste system is required to reduce noise then sound reducing brackets with anti vibration rubber must be used. **If the waste system is constructed using Triplus® or Silere® then the employment of sound insulating pipe brackets is essential.**

### 7.2.2.1 Guide points

The guide points (indicated in the picture with the letter G) are created using brackets which, as well as supporting the weight of the pipe, they allow the axial movement of the pipe, preventing the pipe from flexing due to the increases in length caused by heat expansion, following increases in the temperature of the room and the waste water.

Guide points are created when the bracket is not tightened completely around the circumference of the pipe, giving it free axial movement. Greater details on the use of brackets can be found in section 7.2.7.

**Figure 7.14** Guide point brackets (G).



### 7.2.2.2 Fixed point

Fixed points (indicated in the pictures by the letter F) are also called anchor points and prevent any movement of the pipe in the area where the bracket has been fixed. The aim of fixed points is to divert the variations in length of the pipe in the desired direction, that is, towards the ring seal sockets, the expansion sockets or towards the compensation deviation arms.

Fixed points are usually achieved by using suitable brackets that are closed tightly around the circumference of the pipe. Greater detail on the use of brackets can be found in section 7.2.7.

**Figure 7.15** Fixed point bracket (F).



### 7.2.3 Exposed installation: bracketing using expansion sockets

The installation system using expansion sockets is adopted for Valsir® HDPE pipes in that polyethylene has a higher heat expansion coefficient than other polypropylene based waste systems such as Valsir® PP/PP3, Triplus® and Silere®.

For this type of installation the following simple instructions need to be followed.

The illustrations indicate the most frequent and common cases, however, they are not the only configurations that exist on the building site and other cases will need to be analysed separately.

- For the correct use of the expansion socket refer to section 8.2.2 “Connection using expansion sockets”.
- Straight pipe lengths must be fitted with an expansion socket every 6 m, next to which a fixed point needs to be created, the remaining section of the pipe must be supported and guided by guide brackets. The maximum intervals  $L_1$  to be adopted for the brackets are indicated in the following table and they differ for horizontal and vertical pipes.  $L_1^*$  indicates the maximum distance of the bracket positioned immediately before the expansion socket, for this bracket the distance is less to ensure that the pipe is guided correctly inside the expansion socket.

**Table 7.3** Maximum bracketing intervals for systems with expansion sockets (for HDPE).

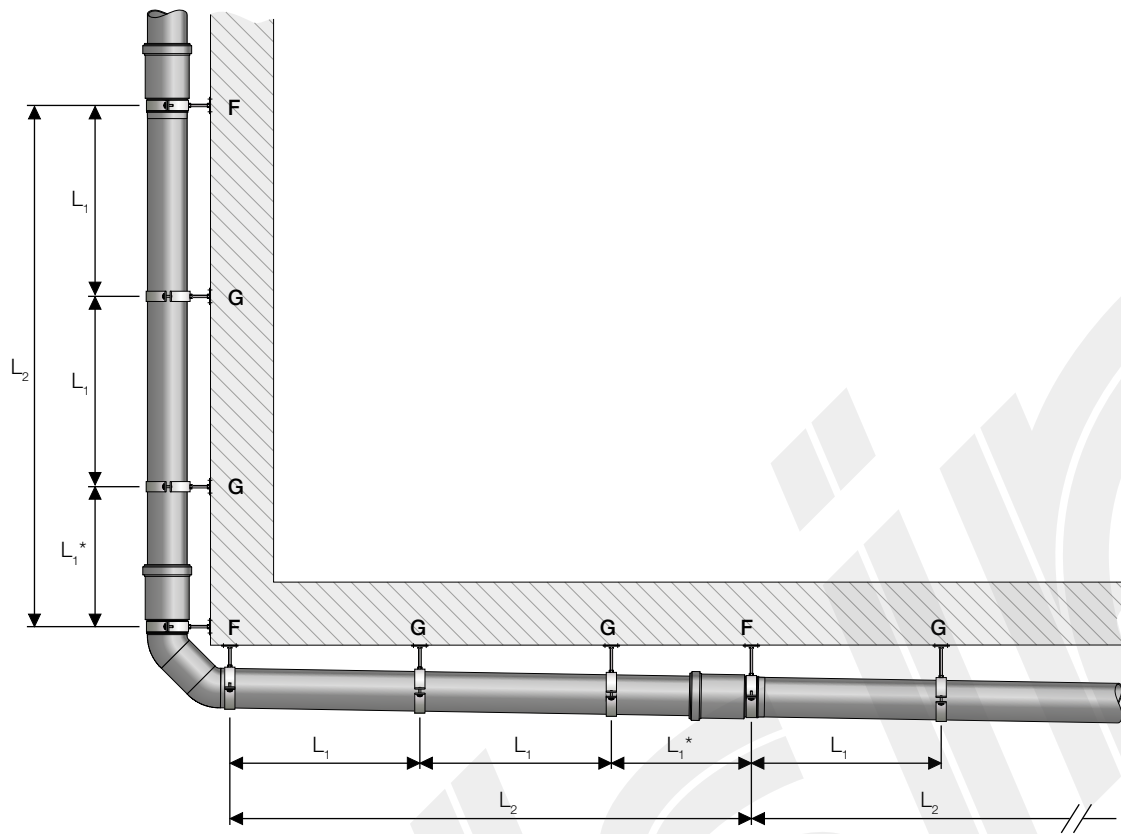
External diameter OD [mm]	Maximum bracketing interval $L_1$ [m]		Maximum bracketing interval $L_1^*$ [m]		Maximum interval between the expansion sockets $L_2$ [m]
	Horizontal pipes <sup>(1)</sup>	Vertical pipes <sup>(2)</sup>	Horizontal pipes <sup>(3)</sup>	Vertical pipes <sup>(3)</sup>	
32	0.8	1.0	0.4	0.5	6
40	0.8	1.0	0.4	0.5	6
50	0.8	1.0	0.4	0.5	6
56	0.8	1.0	0.4	0.5	6
63	0.8	1.0	0.4	0.5	6
75	0.8	1.1	0.4	0.6	6
90	0.9	1.4	0.5	0.7	6
110	1.1	1.7	0.6	0.9	6
125	1.3	1.9	0.7	1.0	6
160	1.6	2.4	0.8	1.2	6
200	2.0	3.0	1.0	1.5	6
250	2.0	3.0	1.0	1.5	6
315	2.0	3.0	1.0	1.5	6

(1) The intervals for horizontal pipes are calculated as  $10 \cdot OD$  with a minimum of 0.8 m and a maximum of 2 m.

(2) The intervals for vertical pipes are calculated as  $15 \cdot OD$  with a minimum of 1 m and a maximum of 3 m.

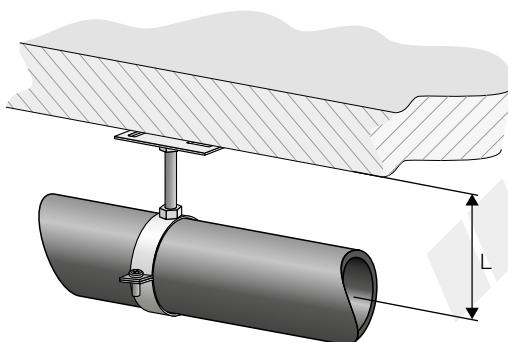
(3) These intervals are calculated roughly as half the bracketing interval  $L_1$ .

Figure 7.16 Installation using expansion sockets (for HDPE).



To choose the threaded rod that connects the bracket to the wall or ceiling, refer to the following tables. The size of the threaded rod depends on the forces caused by the weight of the pipe, the weight of the waste water and therefore in relation to the diameter of the pipe, and on the forces caused by heat expansion, the distance from the wall or ceiling, the position of the pipe (ceiling or wall) and the type of bracket (fixed point or guide point).

**Figure 7.17** Installation distance from ceiling or wall (for HDPE).



**Table 7.4** Ceiling installation (for HDPE).

External diameter OD [mm]	Fixed point (F) or guide point (G)	Distance of pipe axis from the ceiling L [mm]					
		100	200	300	400	500	600
<b>Size of the threaded rod for connection to ceiling</b>							
40	F	M10	1/2"	1/2"	1/2"	1/2"	1/2"
	G	M10	M10	M10	M10	M10	M10
50	F	M10	1/2"	1/2"	1/2"	1/2"	1/2"
	G	M10	M10	M10	M10	M10	M10
56	F	1/2"	1/2"	1/2"	1/2"	1/2"	1/2"
	G	M10	M10	M10	M10	M10	M10
63	F	1/2"	1/2"	1/2"	1/2"	1/2"	1/2"
	G	M10	M10	M10	M10	M10	M10
75	F	1/2"	1/2"	1/2"	1/2"	1/2"	1/2"
	G	M10	M10	M10	M10	M10	M10
90	F	1/2"	1/2"	1/2"	1/2"	3/4"	3/4"
	G	M10	M10	M10	M10	1/2"	1/2"
110	F	1/2"	1/2"	1/2"	3/4"	3/4"	3/4"
	G	M10	M10	M10	1/2"	1/2"	1/2"
125	F	1/2"	1/2"	3/4"	3/4"	3/4"	1"
	G	M10	M10	1/2"	1/2"	1/2"	1/2"
160	F	1/2"	1/2"	3/4"	1"	1"	1"
	G	M10	M10	1/2"	1/2"	1/2"	1/2"
200	F		3/4"	1"	1"	1"	1" 1/4
	G		1/2"	1/2"	1/2"	1/2"	1/2"
250	F		3/4"	1"	1"	1" 1/4	1" 1/4
	G		1/2"	1/2"	1/2"	1/2"	1/2"
315	F		3/4"	1"	1" 1/4	1" 1/4	1" 1/2
	G		1/2"	1/2"	1/2"	1/2"	3/4"

Note. Reductions and threaded rods greater than M10 can be obtained from the threading of standard steel pipes.

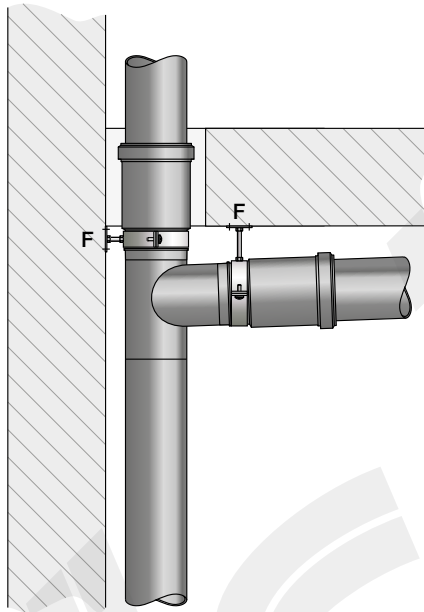
**Table 7.5** Wall installation (for HDPE).

External diameter OD [mm]	Fixed point (F) or guide point (G)	Distance of pipe axis from the wall L [mm]					
		100	200	300	400	500	600
Size of the threaded rod for connection to the wall							
40	F	M10	1/2"	1/2"	1/2"	1/2"	1/2"
	G	M10	M10	M10	M10	M10	1/2"
50	F	1/2"	1/2"	1/2"	1/2"	1/2"	1/2"
	G	M10	M10	M10	M10	1/2"	1/2"
56	F	1/2"	1/2"	1/2"	1/2"	1/2"	1/2"
	G	M10	M10	M10	1/2"	1/2"	1/2"
63	F	1/2"	1/2"	1/2"	1/2"	1/2"	1/2"
	G	M10	M10	M10	1/2"	1/2"	1/2"
75	F	1/2"	1/2"	1/2"	1/2"	1/2"	3/4"
	G	M10	M10	1/2"	1/2"	1/2"	1/2"
90	F	1/2"	1/2"	1/2"	1/2"	3/4"	3/4"
	G	M10	1/2"	1/2"	1/2"	1/2"	1/2"
110	F	1/2"	1/2"	1/2"	3/4"	3/4"	1"
	G	M10	1/2"	1/2"	1/2"	1/2"	1/2"
125	F	1/2"	1/2"	3/4"	3/4"	1"	1"
	G	M10	1/2"	1/2"	1/2"	1/2"	1/2"
160	F	1/2"	3/4"	3/4"	1"	1"	1"
	G	M10	1/2"	1/2"	1/2"	1/2"	1/2"
200	F		3/4"	1"	1"	1" 1/4	1" 1/4
	G		1/2"	1/2"	1/2"	3/4"	3/4"
250	F		3/4"	1"	1" 1/4	1" 1/4	1" 1/4
	G		1/2"	1/2"	3/4"	3/4"	3/4"
315	F		3/4"	1"	1" 1/4	1" 1/2	1" 1/2
	G		1/2"	1/2"	3/4"	1"	1"

Note. Reductions and threaded rods greater than M10 can be obtained from the threading of standard steel pipes.

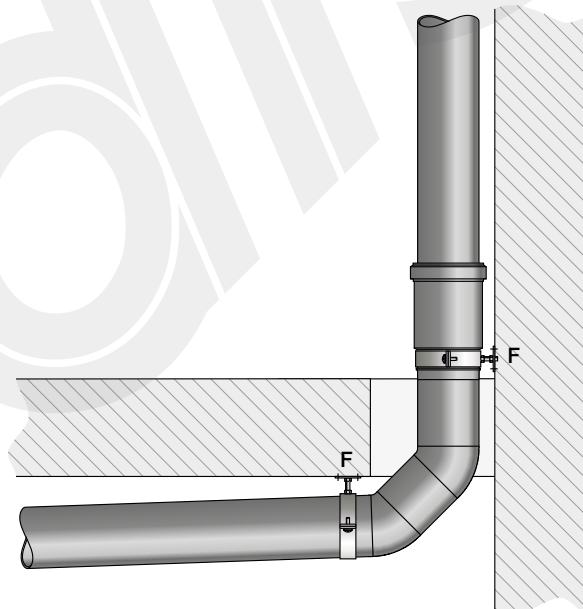
- For branches and direction changes, the methods indicated in paragraph 7.2.5 “Exposed installation: bracketing with compensation of expansions” can be used as an alternative to the following rules.
- When branch connections exist an anchor point must be installed to avoid movements in the branching point, it is therefore necessary to install expansion sockets at the inlet connections with fixed point brackets (Figure 7.18).

**Figure 7.18** Anchor point in the presence of a branch connection (for HDPE).



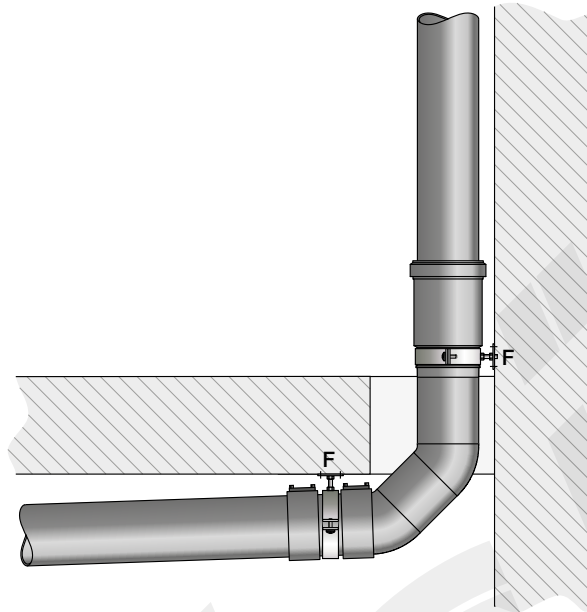
- Where there is a change in direction an anchor point must be created and therefore the installation of an expansion socket is required at the inlet connection of the bend with relative fixed point brackets (Figure 7.19).

**Figure 7.19** Anchor points in the presence of direction changes (for HDPE).

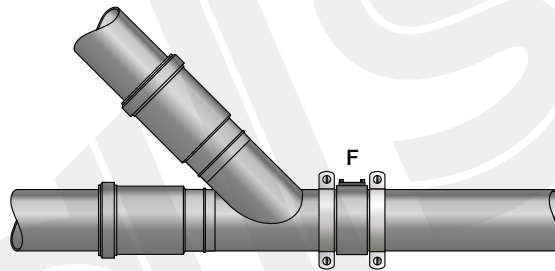


- Anchor points can also be created by using guide point brackets, for example, by positioning a guide point bracket between two electrofusion sleeves (Figure 7.20) or by placing an electrofusion sleeve between two guide point brackets (Figure 7.21).

**Figure 7.20** Anchor point with a guide bracket and two electrofusion sleeves (for HDPE).

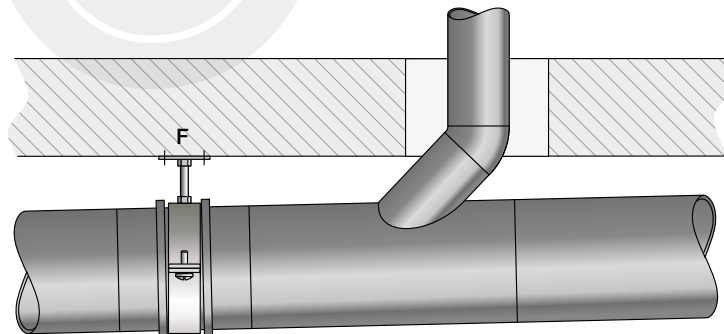


**Figure 7.21** Anchor point with two guide brackets and an electrofusion sleeve (for HDPE).



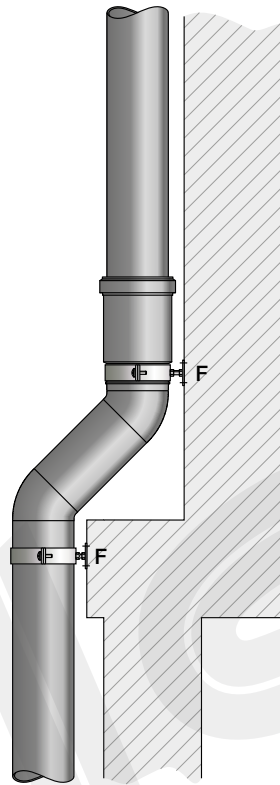
- To create an anchor point on large diameter pipes ( $OD \geq 200$  mm) it is possible to use a guide bracket together with a double flange bushing (Figure 7.22).

**Figure 7.22** Creation of a fixed point on large diameter pipes using a double flange bushing (for HDPE).

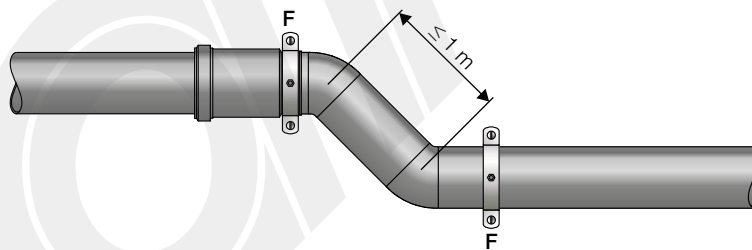


- Deviations, both in a stack and in horizontal pipes, must be equipped with anchor points (Figure 7.23). If the deviation is smaller or equal to 1 m two fixed point brackets before and after the deviation and an expansion socket at the inlet of the deviation will be required (Figure 7.24). Deviations greater than 1 m are straight lengths of pipe and are to be considered as such, expansion sockets, fixed points and guide points are therefore necessary at the intervals specified in Table 7.8 (Figure 7.25).

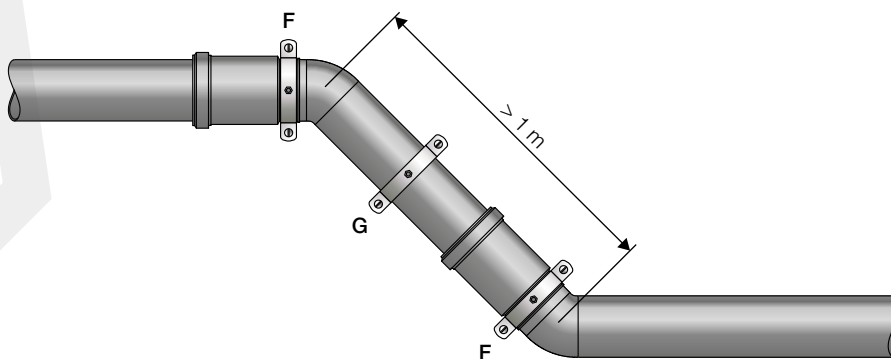
**Figure 7.23** Deviation (for HDPE).



**Figure 7.24** Anchor points on deviations smaller than or equal to 1 m (for HDPE).



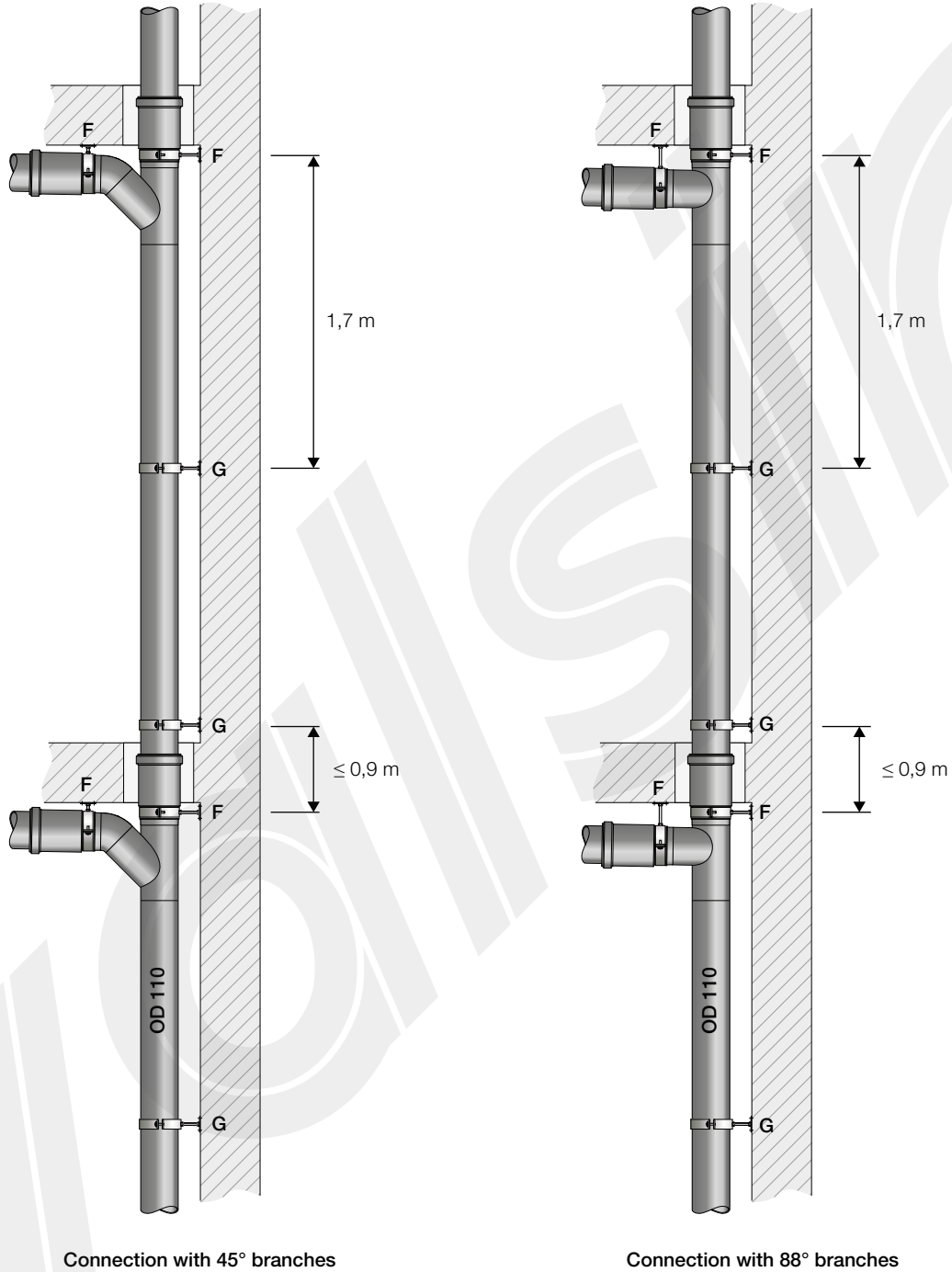
**Figure 7.25** Anchor points on deviations greater than 1 m (for HDPE).



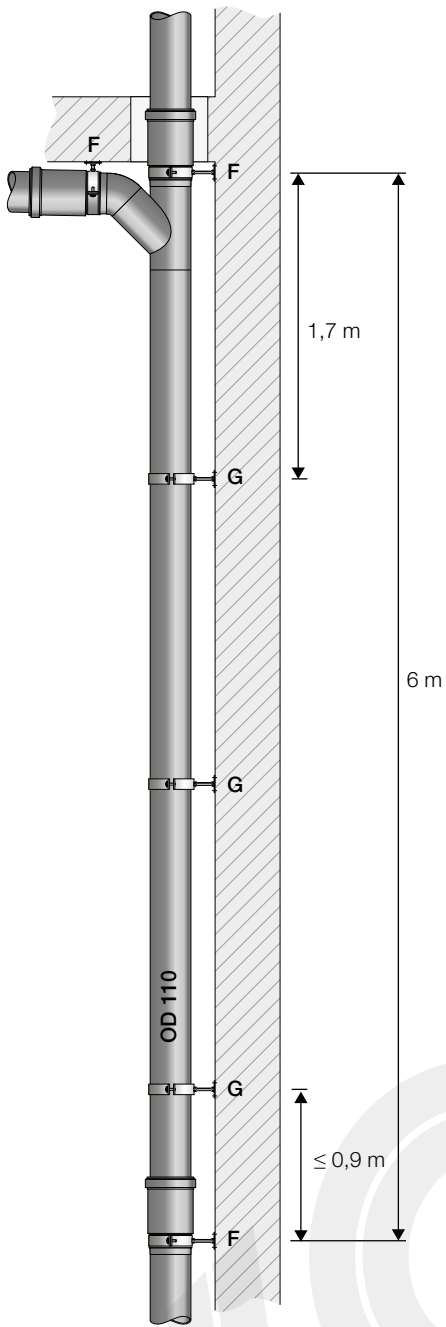


- As with horizontal collector pipes, anchor points need to be created for each inlet branch (Figure 7.28), the bracketing intervals are those indicated in Table 7.8. If the distance between one branch and another is greater than 6 m (Figure 7.29) intermediate expansion sockets need to be installed, at intervals no greater than 6 m from each other, as indicated at the start of the section. The anchor point for each branch can be created by using fixed point brackets or (if compatible with construction constraints) by embedding the branch directly in the concrete slab (Figure 7.30).

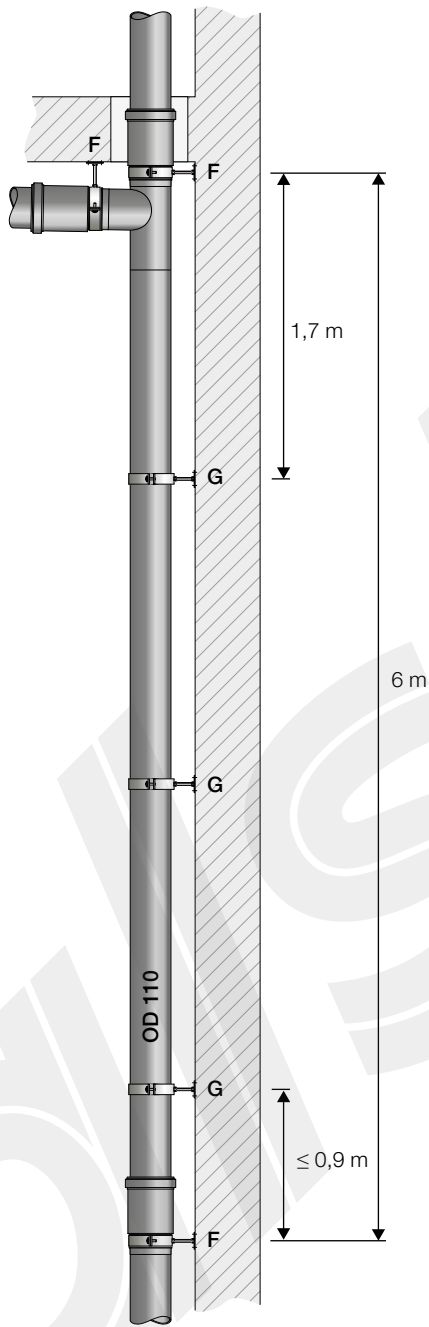
**Figure 7.28** Stack OD=110 mm with inlet branches at intervals less than 6 m (for HDPE).



**Figure 7.29** Stack OD=110 mm with inlet branches at intervals greater than 6 m (for HDPE).

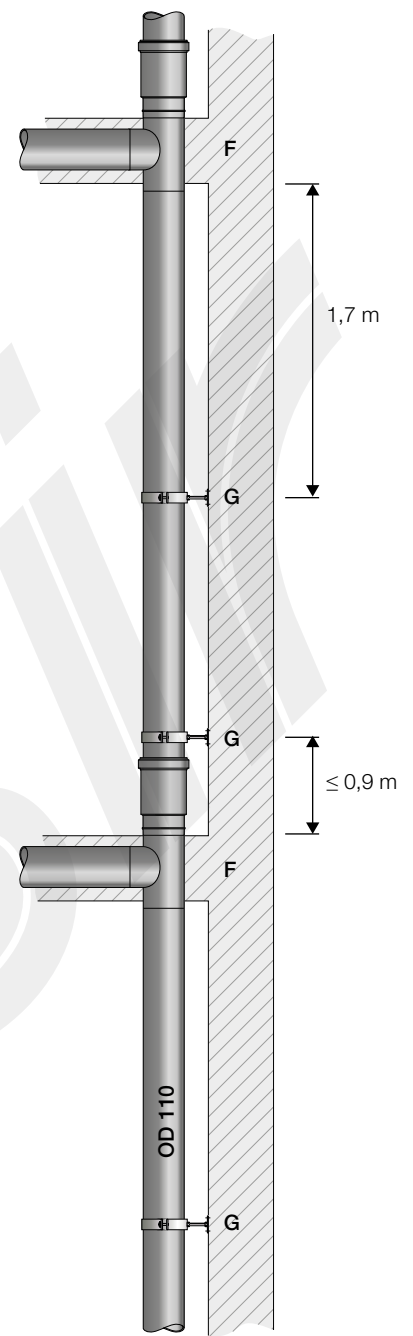


Connection with 45° branches



Connection with 88° branches

**Figure 7.30** Stack OD=110 mm with inlet branches embedded in the slab (for HDPE).

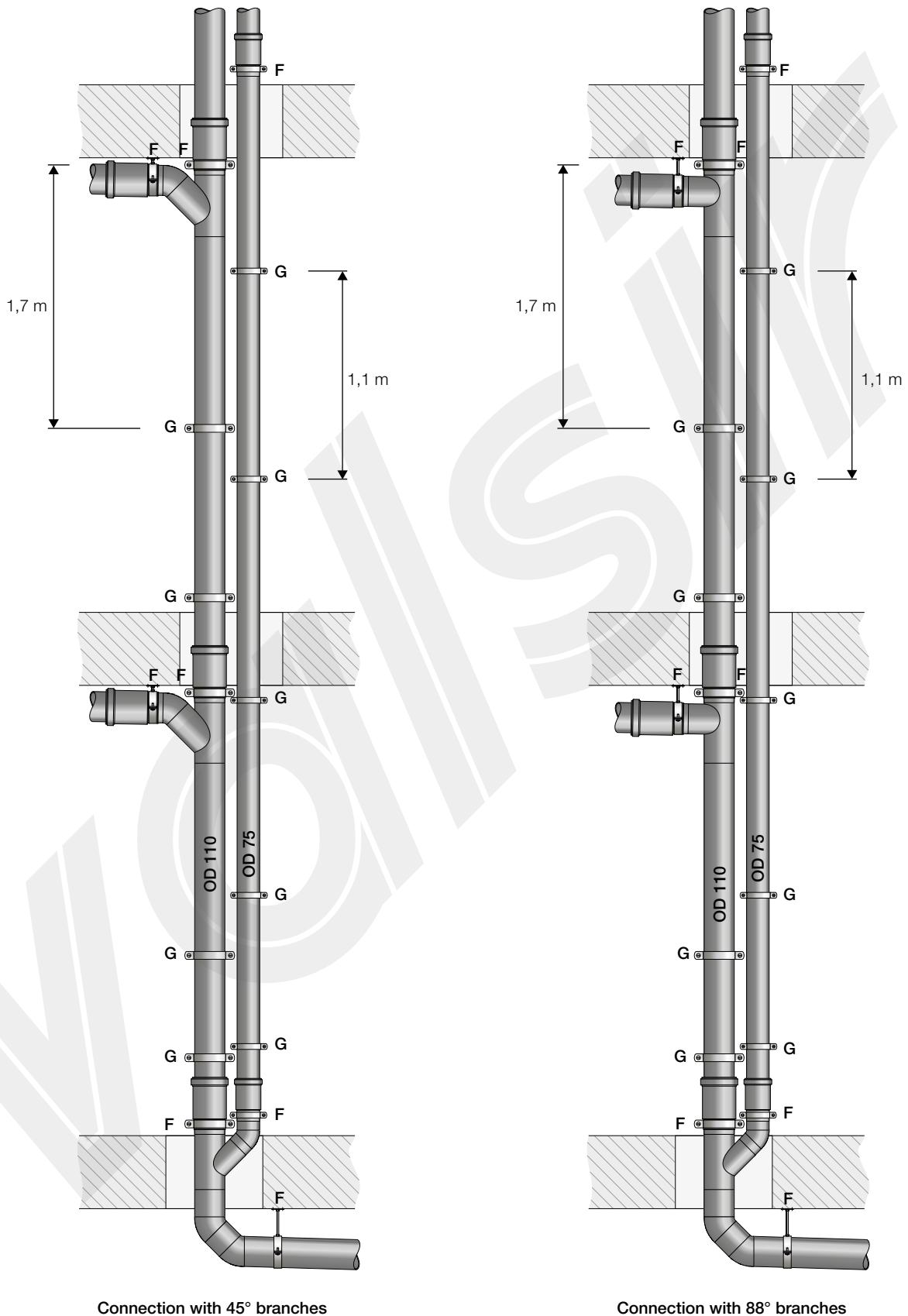


Connection with 88° branches

7

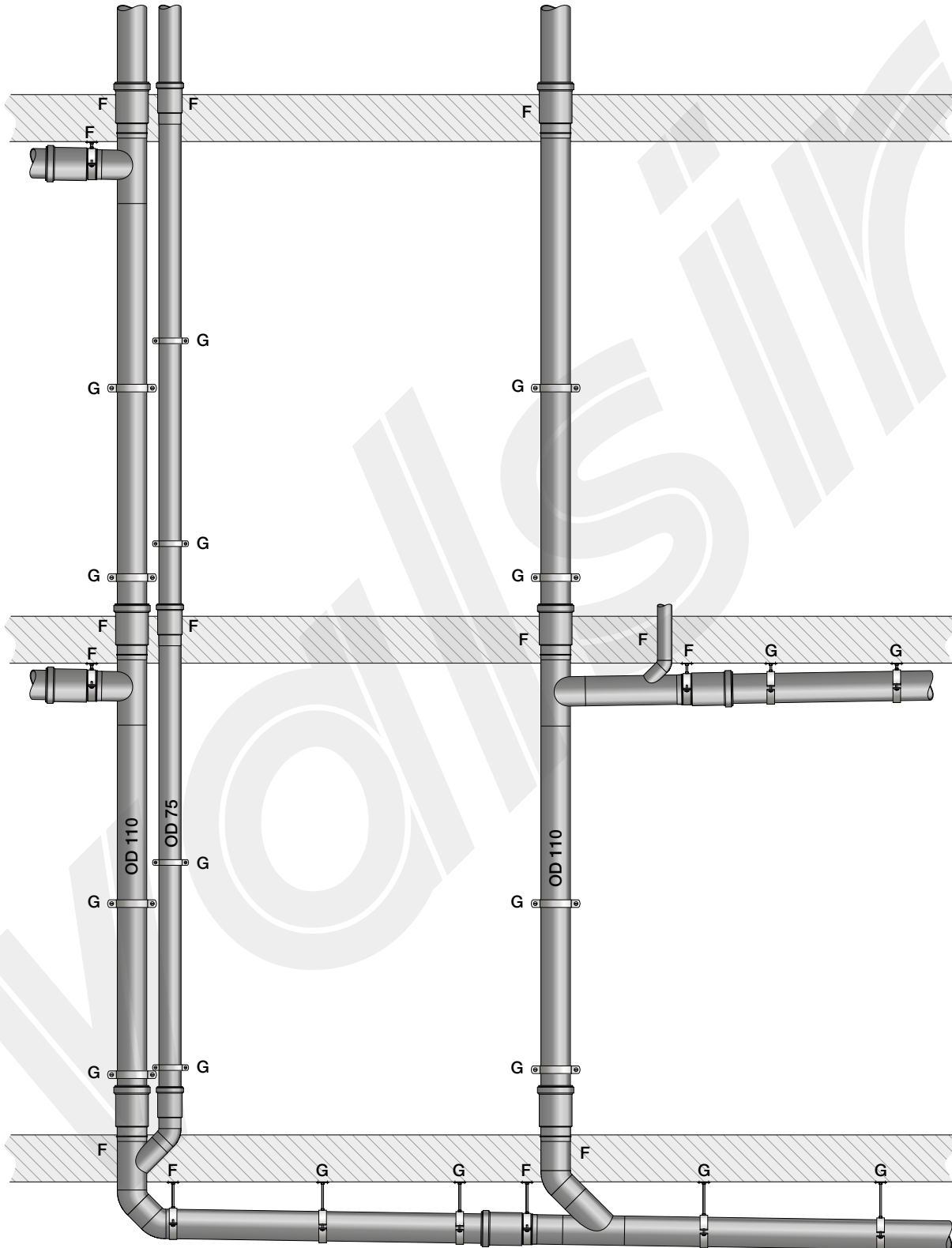
- The rules specified for collector pipes and soil stacks also apply to ventilation networks. The ventilation stack must be suitably bracketed with anchor points at the expansion sockets and guide points at distances that depend on the diameter of the pipe as indicated in Table 7.8. As with soil stacks, when there are no changes of direction and no branches in the ventilation stacks, expansion sockets must be installed at least every 6 m (Figure 7.31).

**Figure 7.31** Stack OD=110 mm with parallel ventilation OD=75 mm (for HDPE).



- The above rules are general and therefore are to be applied according to the individual system configurations. In the example in Figure 7.32 the soil stacks are characterised by expansion sockets laid directly inside the slab and therefore they constitute anchor points. Also the ventilation stack is characterised by anchor points on each floor and therefore the use of expansion sockets is required. For the inlet branches, when they are not completely embedded in the slab, the addition of a fixed point bracket is necessary, in particular, in the case of reduced branches where the branching has a small diameter.

**Figure 7.32** Example of system layout (for HDPE).



## 7.2.4 Exposed installation: bracketing using push-fit sockets

The Valsir® PP/PP3, Triplus® and Silere® waste systems have a reduced heat expansion coefficient in comparison with the Valsir® HDPE waste system. The use of expansion sockets is not required for these systems, the sockets themselves are in fact sufficient to compensate for the variations in length of the pipes.

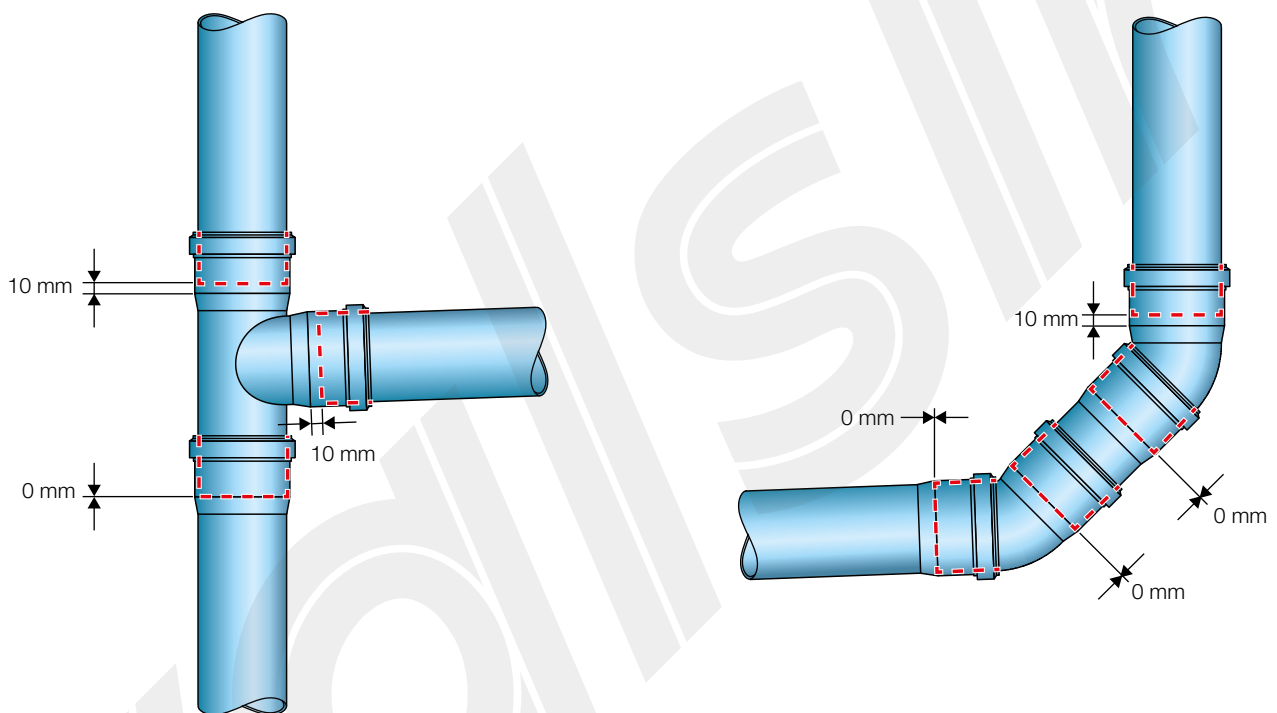
When these systems are used, given the maximum length of the available pipes, there are push-fit sockets maximum every 3 m; such an interval does not produce a significant extension even in the presence of substantial temperature variations.

The following illustrations indicate the most frequent and common cases, however, they are not the only configurations that exist on the building site and other cases will need to be analysed separately.

The illustrations show the Triplus® waste system, however, they are also valid for the other waste systems with push-fit sockets such as PP/PP3 and Silere®.

- When installing waste system using push-fit sockets, remember that the fittings must be inserted to maximum socket depth whereas the pipes, when they have been fully inserted, must then be pulled back by 10 mm as shown in Figure 7.33 (for more information refer to section 8.2.1 “Joining with push-fit sockets”).

**Figure 7.33** Examples of a correct use of the push-fit socket (for PP/PP3, Triplus® and Silere®).



- For straight lengths of pipe, a fixed point must be created for each push-fit socket of the pipework, the remaining part of the pipework of the fittings will be supported and guided by guide point brackets (with the exception of particular configurations that need to be analysed separately). The maximum intervals  $L_1$  to be adopted for the brackets are shown in the following table and they are different for horizontal and vertical pipes.

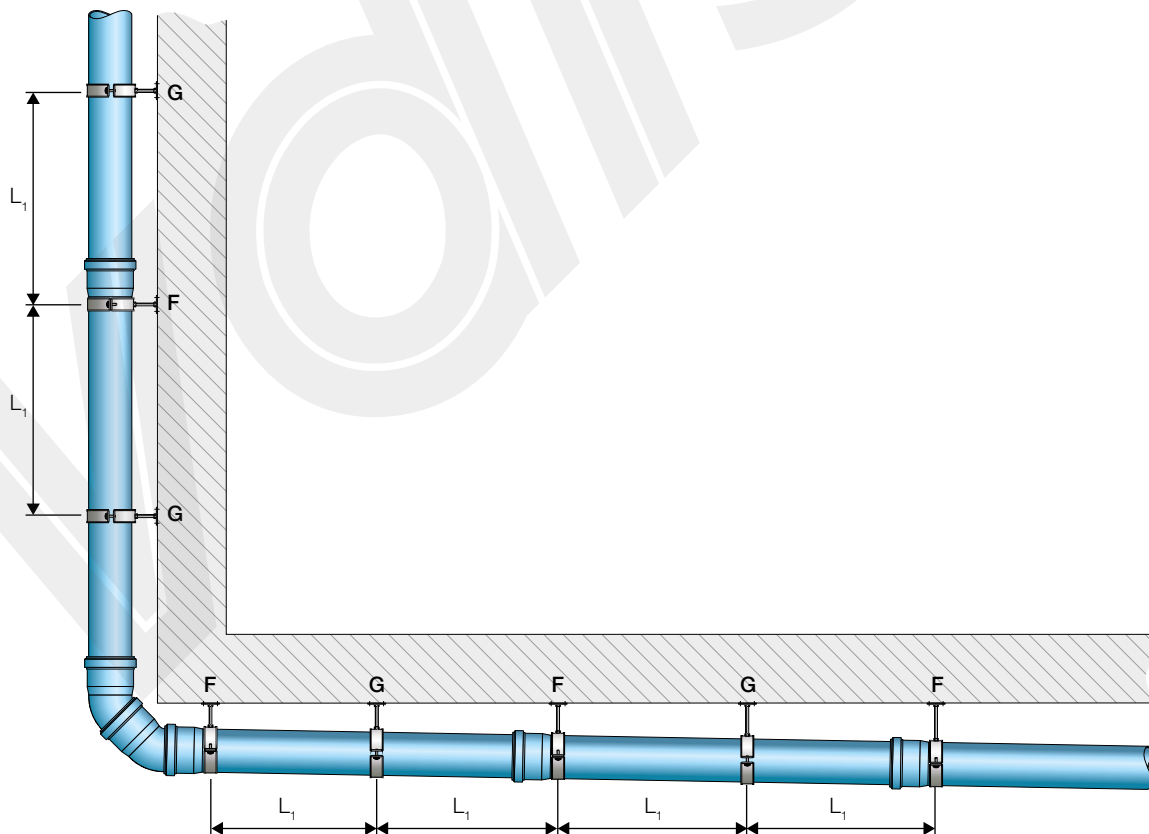
**Table 7.6** Maximum bracketing intervals for push-fit socket systems (for PP/PP3, Triplus® and Silere®).

External diameter OD [mm]	Maximum bracketing interval $L_1$ [m]	
	Horizontal pipes <sup>(1)</sup>	Vertical pipes <sup>(2)</sup>
32	0.8	1.0
40	0.8	1.0
50	0.8	1.0
58	0.8	1.0
75	0.8	1.1
78	0.8	1.2
90	0.9	1.4
110	1.1	1.7
125	1.3	1.9
135	1.3	2.0
160	1.6	2.4
200	2.0	3.0
250	2.0	3.0

(1) The intervals for horizontal pipes are calculated as 10-OD with a minimum of 0.8 m and a maximum of 2 m.

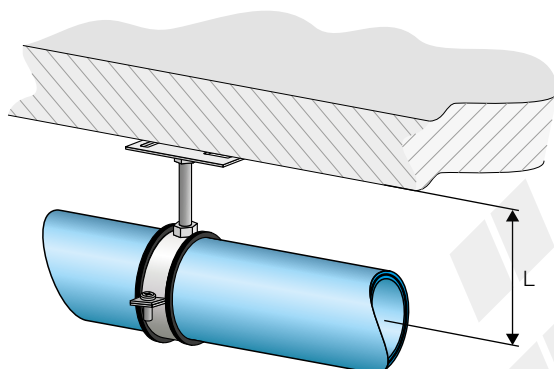
(2) The intervals for vertical pipes are calculated as 15-OD with a minimum of 1 m and a maximum of 3 m.

**Figure 7.34** Installation using push-fit sockets (for PP/PP3, Triplus® and Silere®).



- For the choice of the threaded rod to connect the bracket to the wall or ceiling, refer to the following tables. The size of the threaded rod depends on the forces caused by the weight of the pipe, the weight of the waste water and the forces caused by heat expansion and therefore depends on the diameter of the pipe, its distance from the wall or ceiling, the position of the pipe (wall or ceiling) and the type of bracket (fixed point or guide point).

**Figure 7.35** Installation distance on wall or ceiling (for PP/PP3, Triplus® and Silere®).



**Table 7.7** Ceiling installation (for PP/PP3, Triplus® and Silere®).

External diameter OD [mm]	Fixed point (F) or guide point (G)	Distance of pipe axis from the ceiling L [mm]					
		100	200	300	400	500	600
<b>Size of the threaded rod for connection to ceiling</b>							
40	F	M10	M10	M10	1/2"	1/2"	1/2"
	G	M10	M10	M10	M10	M10	M10
50	F	M10	M10	M10	1/2"	1/2"	1/2"
	G	M10	M10	M10	M10	M10	M10
58	F	M10	M10	M10	1/2"	1/2"	1/2"
	G	M10	M10	M10	M10	M10	M10
75/78	F	M10	M10	1/2"	1/2"	1/2"	1/2"
	G	M10	M10	M10	M10	M10	M10
90	F	M10	1/2"	1/2"	1/2"	1/2"	1/2"
	G	M10	M10	M10	M10	1/2"	1/2"
110	F	M10	1/2"	1/2"	1/2"	1/2"	1/2"
	G	M10	M10	M10	1/2"	1/2"	1/2"
125	F	M10	1/2"	1/2"	1/2"	1/2"	1/2"
	G	M10	M10	1/2"	1/2"	1/2"	1/2"
135	F	M10	1/2"	1/2"	1/2"	1/2"	1/2"
	G	M10	M10	1/2"	1/2"	1/2"	1/2"
160	F	M10	1/2"	1/2"	1/2"	1/2"	3/4"
	G	M10	M10	1/2"	1/2"	1/2"	1/2"
200	F		1/2"	1/2"	1/2"	3/4"	3/4"
	G		1/2"	1/2"	1/2"	1/2"	1/2"
250	F		1/2"	1/2"	3/4"	3/4"	1"
	G		1/2"	1/2"	1/2"	1/2"	1/2"

Note. Reductions and threaded rods greater than M10 can be obtained from the threading of standard steel pipes.

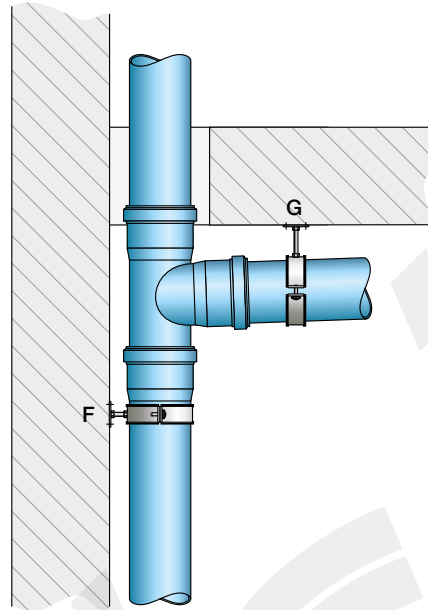
**Table 7.8** Wall installation (for PP/PP3, Triplus® and Silere®).

External diameter OD [mm]	Fixed point (F) or guide point (G)	Distance of pipe axis from the wall L [mm]					
		100	200	300	400	500	600
Size of the threaded rod for connection to wall							
40	F	M10	M10	1/2"	1/2"	1/2"	1/2"
	G	M10	M10	M10	M10	M10	M10
50	F	M10	M10	1/2"	1/2"	1/2"	1/2"
	G	M10	M10	M10	M10	M10	M10
58	F	M10	M10	1/2"	1/2"	1/2"	1/2"
	G	M10	M10	M10	M10	M10	M10
75/78	F	M10	M10	1/2"	1/2"	1/2"	1/2"
	G	M10	M10	M10	M10	M10	1/2"
90	F	M10	1/2"	1/2"	1/2"	1/2"	1/2"
	G	M10	M10	M10	1/2"	1/2"	1/2"
110	F	M10	1/2"	1/2"	1/2"	1/2"	1/2"
	G	M10	M10	1/2"	1/2"	1/2"	1/2"
125	F	M10	1/2"	1/2"	1/2"	1/2"	1/2"
	G	M10	M10	1/2"	1/2"	1/2"	1/2"
135	F	M10	1/2"	1/2"	1/2"	1/2"	1/2"
	G	M10	1/2"	1/2"	1/2"	1/2"	1/2"
160	F	M10	1/2"	1/2"	1/2"	3/4"	3/4"
	G	M10	1/2"	1/2"	1/2"	1/2"	1/2"
200	F		1/2"	1/2"	3/4"	3/4"	3/4"
	G		1/2"	1/2"	1/2"	1/2"	1/2"
250	F		1/2"	3/4"	3/4"	1"	1"
	G		1/2"	1/2"	1/2"	3/4"	3/4"

Note. Reductions and threaded rods greater than M10 can be obtained from the threading of standard steel pipes.

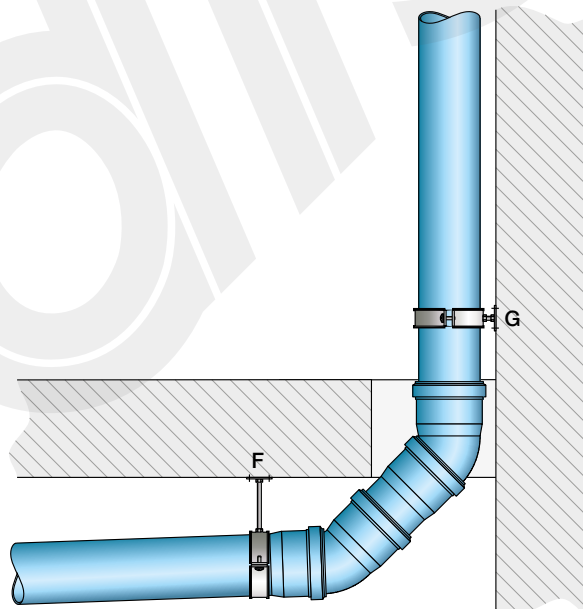
- When branch connections exist an anchor point must be created to avoid movements in the branching point, it is therefore necessary to install a fixed point bracket on the pipe socket where the branch itself has been fitted (Figure 7.36). On the incoming pipes connected to the branch, guide point brackets must be applied at the intervals specified in Table 7.6.

**Figure 7.36** Anchor point in the presence of a branch (for PP/PP3, Triplus® and Silere®).



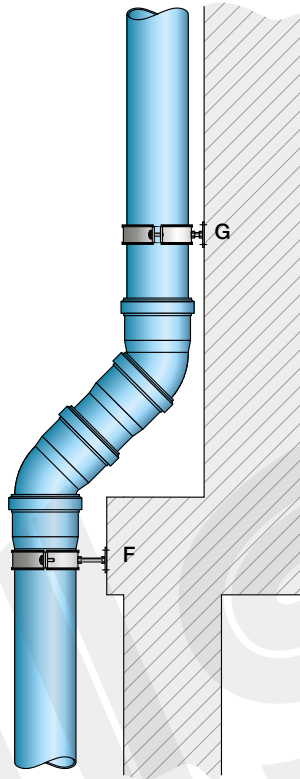
- In the presence of a change of direction an anchor point must be created and therefore the installation of a fixed point bracket on the socket of the pipe where the last bend has been connected (Figure 7.37). Guide point brackets must be applied to the inlet pipe attached to the bend at the distances specified in Table 7.6.

**Figure 7.37** Anchor point in the presence of direction changes (for PP/PP3, Triplus® and Silere®).

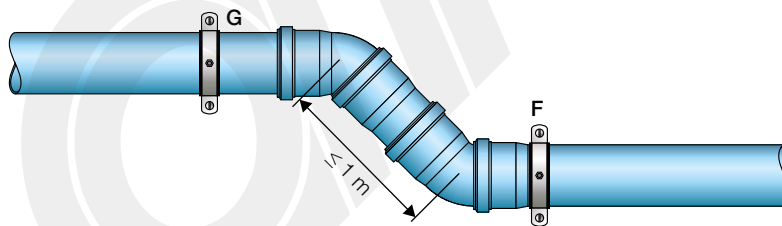


- Deviations, either in the stack or in horizontal pipes, must be equipped with anchor points (Figure 7.38). If the deviation is less than or equal to 1 m a fixed point brackets is required on the socket of the pipe immediately following the last bend that forms the deviation. The pipe that is connected to the first bend that forms the deviation must be supported and guided with a guide point bracket (Figure 7.39). Deviations that are greater than 1 m are straight lengths of pipe and are to be considered as such, fixed points are therefore necessary at the sockets of the pipes and guide points at the intervals specified in Table 7.8 (Figure 7.40).

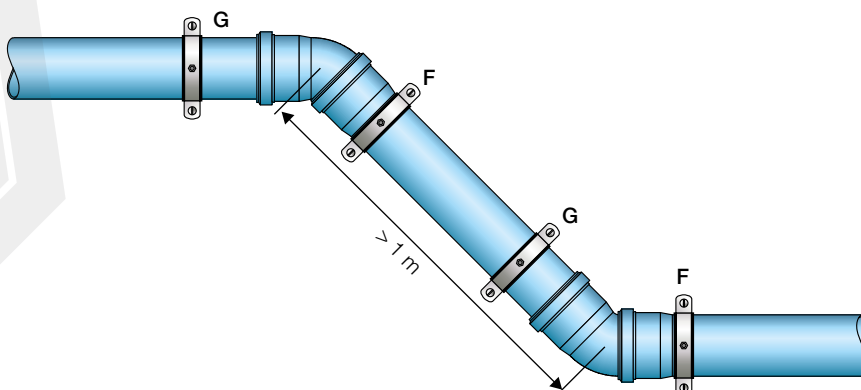
**Figure 7.38** Deviation (for PP/PP3, Triplus® and Silere®).



**Figure 7.39** Anchor points on deviations that are smaller than or equal to 1 m (for PP/PP3, Triplus® and Silere®).

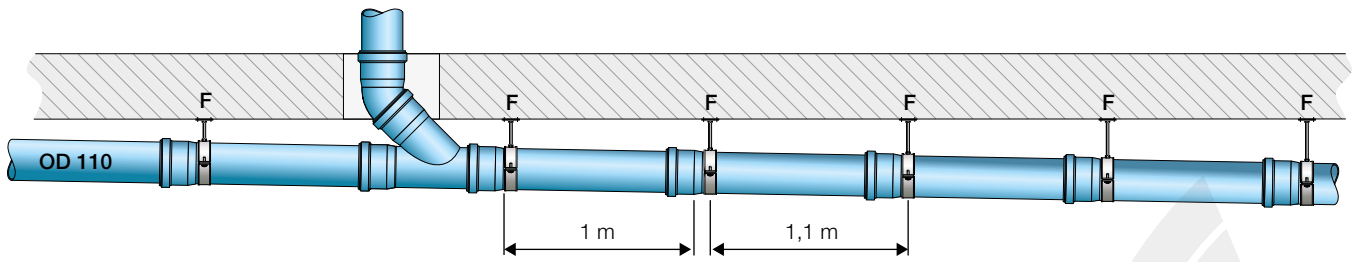


**Figure 7.40** Anchor points on deviations that are greater than 1 m (for PP/PP3, Triplus® and Silere®).

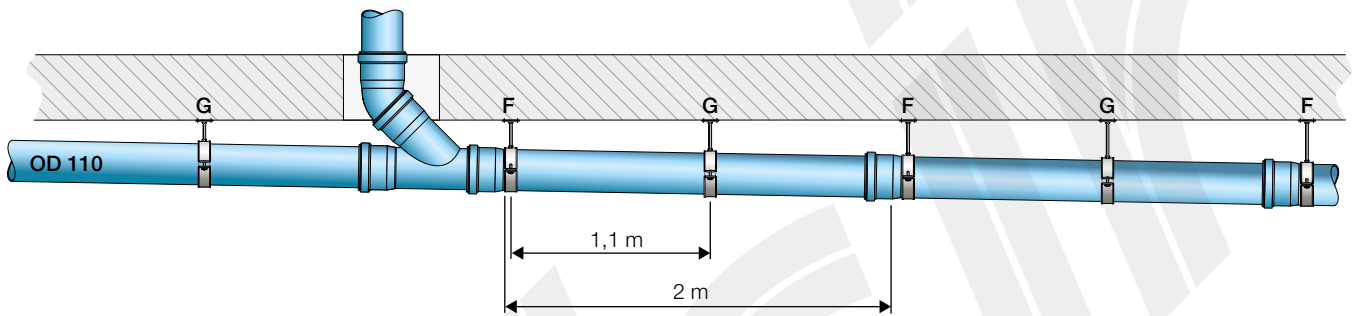


- On horizontal collector pipes, anchor points must be created for each pipe socket (Figure 7.41, Figure 7.42, Figure 7.43), the bracketing distances must always be as indicated in Table 7.8.

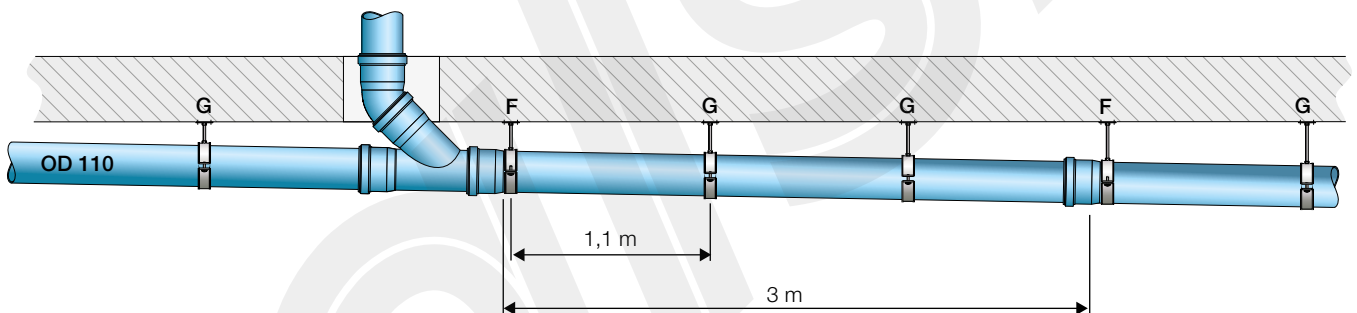
**Figure 7.41** Horizontal collector pipe OD=110 mm composed of 1 m length pipes (for PP/PP3, Triplus® and Silere®).



**Figure 7.42** Horizontal collector pipe OD=110 mm composed of 2 m length pipes (for PP/PP3, Triplus® and Silere®).



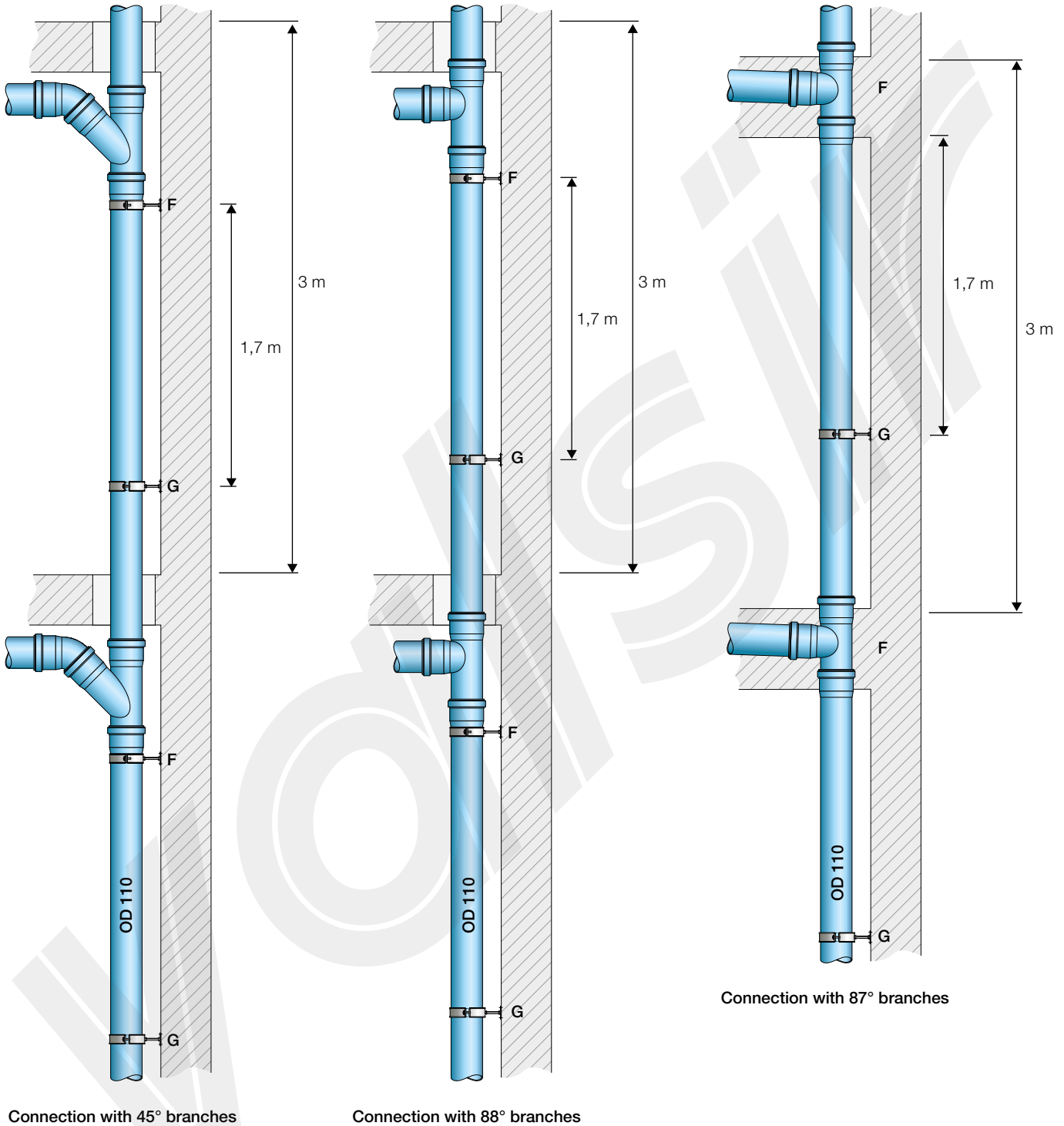
**Figure 7.43** Horizontal collector pipe OD=110 mm composed of 3 m length pipes (for PP/PP3, Triplus® and Silere®).



- On stacks, anchor points must be created for each inlet branch using a fixed point bracket on the socket of the pipe where the branch is connected (Figure 7.44), the bracketing intervals must be those as indicated in Table 7.8. The anchor point for each branch can be created by embedding the branch directly in the concrete slab, if compatible with construction constraints (Figure 7.45).

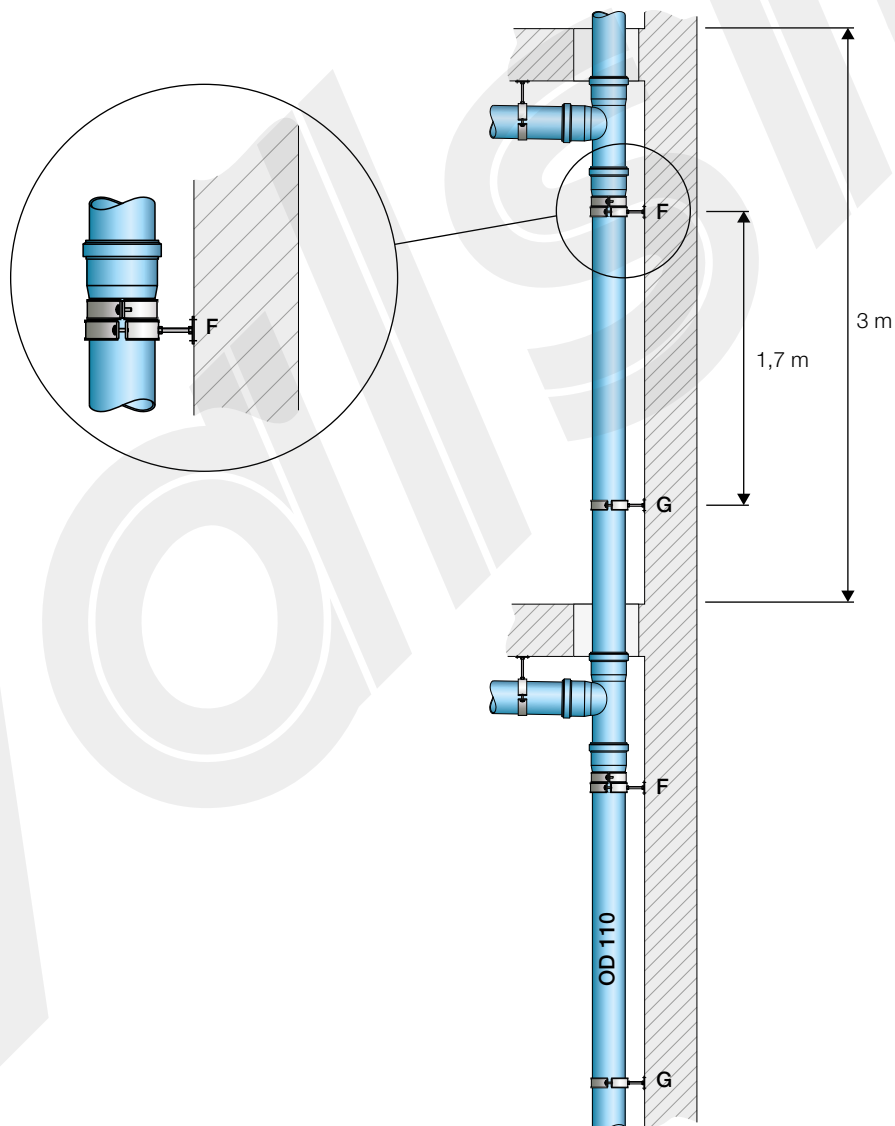
**Figure 7.44** OD=110 mm stack with inlet branch under the slab (for PP/PP3, Triplus® and Silere®).

**Figure 7.45** OD=110 mm stack with inlet branches embedded in the slab (for PP/PP3, Triplus® and Silere®).



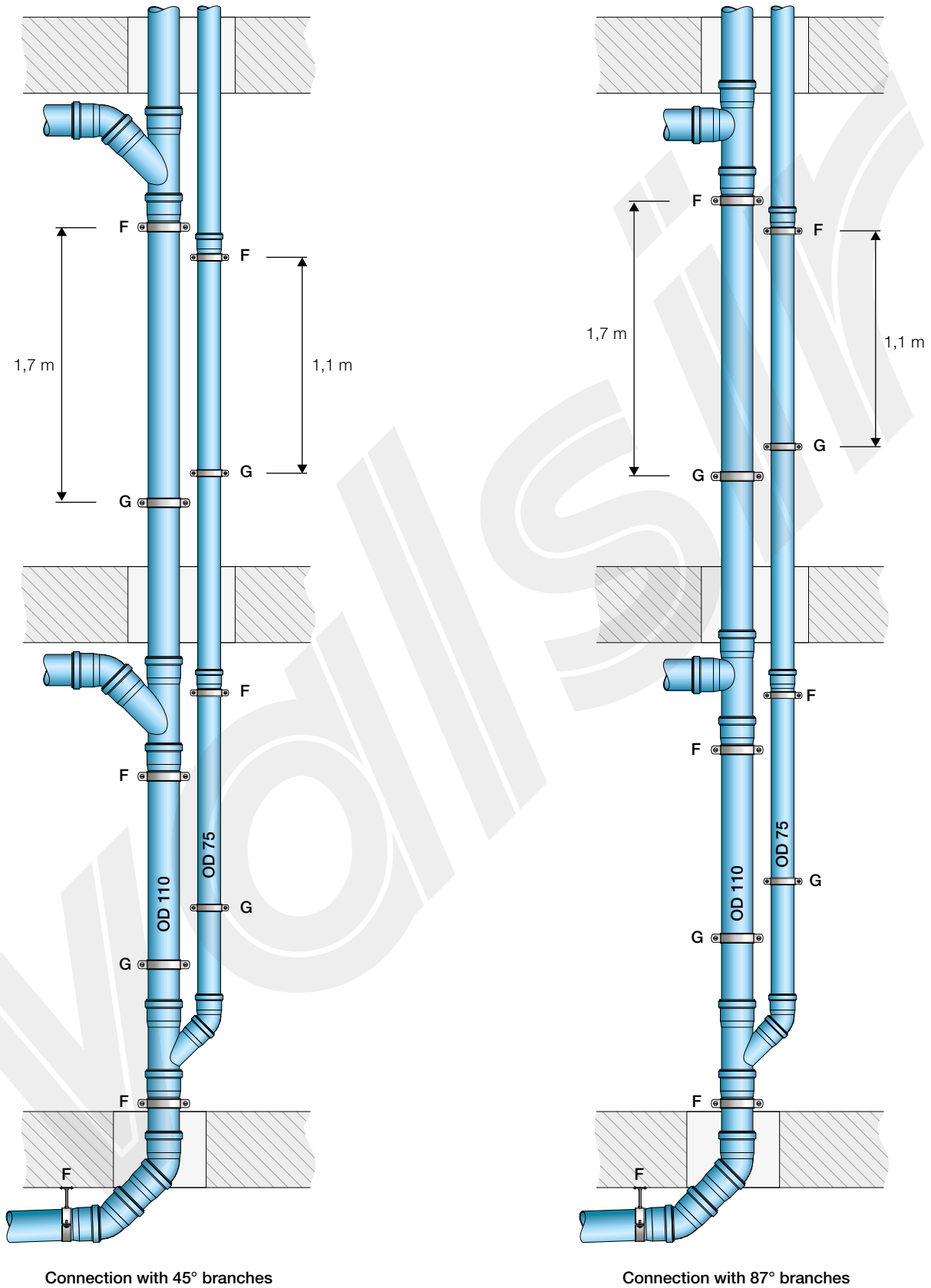
- In order to obtain the sound reducing performance measured in the CSIRO laboratory in Melbourne - Australia (Test Report 5116.1.2L) and to install the pipes in the acoustic insulation conditions specified (see section 2.7 “Acoustic performance of Valsir waste pipes® in compliance with the Building Code of Australia”) the soil stacks must be installed by using high performance sound reducing anchor points.
- It should be noted that the adoption of such bracketing techniques is not the only element that influences the acoustic performance, the quality of the installation of the entire waste system remains the dominant factor.
- The high performance acoustic anchor points are made up of the connection of two brackets equipped with antivibration rubber (Figure 7.46): the first is connected to the wall of the building and must not be tightened around the pipe (like a guide point bracket), the second one is closed tightly around the pipe (like a fixed point bracket) and has the task of discharging the weight of the pipe on to the lower bracket. When the soil stack is full, the vibrations are cushioned by the contact surface between the antivibration rubber of the two brackets, thus preventing the movements of the pipe from being transferred from the lower bracket to the building structure.
- A high performance sound reducing fixed point needs to be installed for each floor of the building, the distances between the remaining guide points must be in compliance with the rules indicated previously in this section (Figure 7.46).
- More information on the creation of high performance acoustic fixed points can be found in section 7.2.7.

**Figure 7.46** OD=110 mm stack with high performance acoustic anchor points (for Triplus® and Silere®).



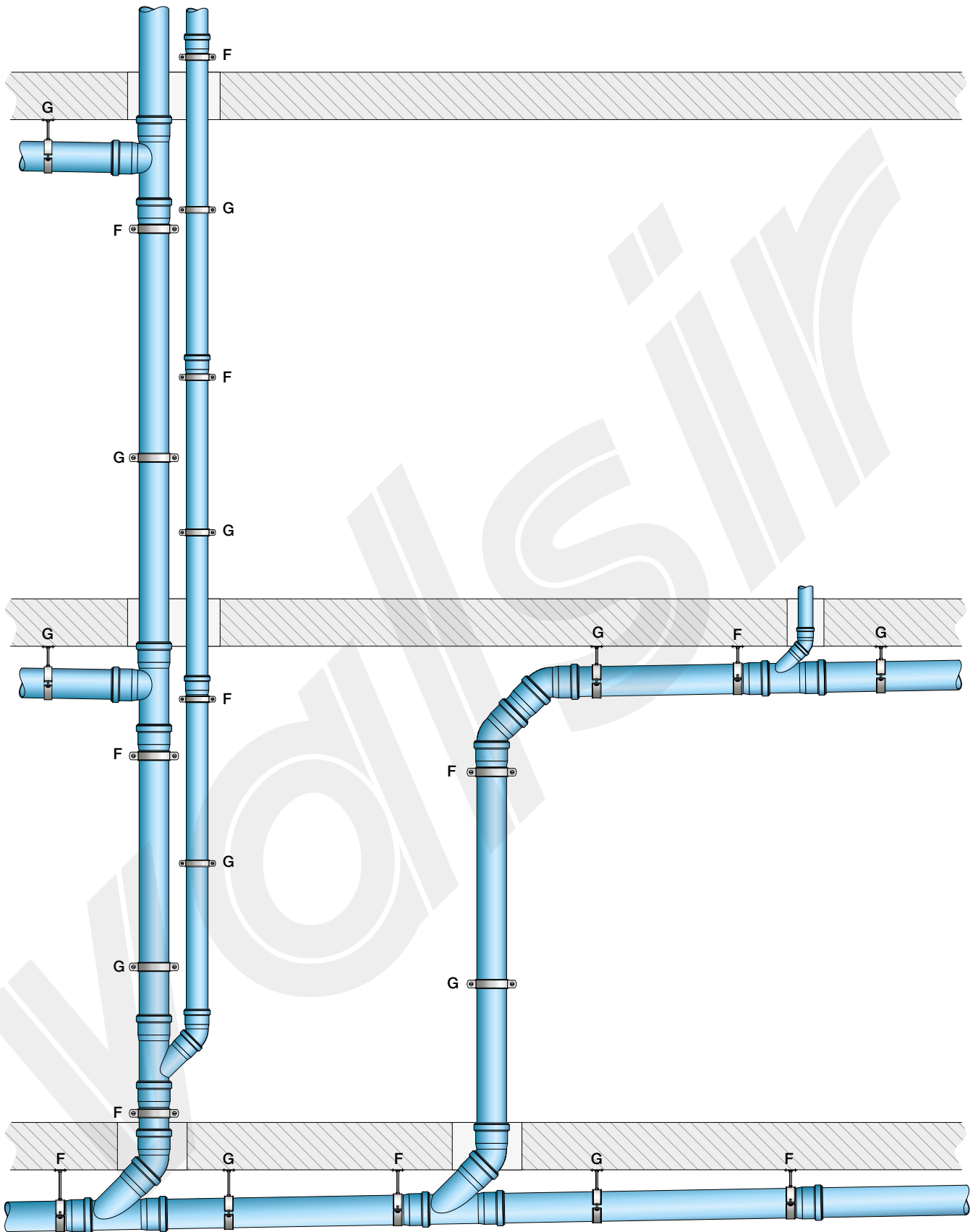
- The rules indicated for the collector pipes and soil stacks are valid also for ventilation networks. The ventilation stack must be suitably bracketed with anchor points at the push-fit sockets of the pipes and with guide points at intervals that depend on the diameter of the pipe as indicated in Table 7.8 (Figure 7.47). High performance acoustic fixed points are not required for ventilation stacks.

**Figure 7.47** OD=110 mm stack with parallel ventilation OD=75 mm (for PP/PP3, Triplus® and Silere®).



- The abovementioned rules are therefore applied on the whole, but always in compliance with the single system configurations, an example is given in Figure 7.48.

**Figure 7.48** Example of system layout (for PP/PP3, Triplus® and Silere®).



## 7.2.5 Exposed installation: bracketing with compensation of expansions

Installation with a flexible arm allows the flexing capacity of the pipe to be used to absorb the variations in length thus avoiding the use of expansion sockets or push-fit sockets; it is therefore an installation that is suitable for the Valsir® HDPE waste system when it is installed with welded joints. For this type of bracketing the intervals to be observed for the brackets are indicated in the following table.

**Table 7.9** Minimum bracketing intervals for system with expansion compensation (for HDPE).

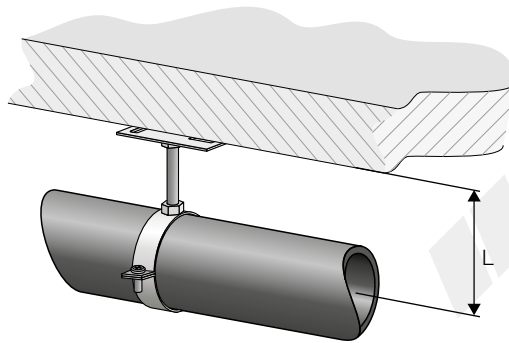
External diameter OD [mm]	Maximum bracketing interval $L_1$ [m]	
	Horizontal pipes <sup>(1)</sup>	Vertical pipes <sup>(2)</sup>
32	0.8	1.0
40	0.8	1.0
50	0.8	1.0
56	0.8	1.0
63	0.8	1.0
75	0.8	1.1
90	0.9	1.4
110	1.1	1.7
125	1.3	1.9
160	1.6	2.4
200	2.0	3.0
250	2.0	3.0
315	2.0	3.0

(1) The intervals for horizontal pipes are calculated as  $10 \cdot OD$  with a minimum of 0.8 m and a maximum of 2 m.

(2) The intervals for vertical pipes are calculated as  $15 \cdot OD$  with a minimum of 1 m and a maximum of 3 m.

For the choice of the threaded rod to connect the bracket to the wall or ceiling, refer to the following tables. The size of the threaded rod depends on the forces caused by the weight of the pipe, the weight of the waste water and the forces caused by heat expansion and therefore depends on the diameter of the pipe, its distance from the wall or ceiling, the position of the pipe (wall or ceiling) and the type of bracket (fixed point or guide point).

**Figure 7.49** Ceiling or wall installation distance (for HDPE).



**Table 7.10** Ceiling installation (for HDPE).

External diameter OD [mm]	Fixed point (F) or guide point (G)	Distance of pipe axis from ceiling L [mm]					
		100	200	300	400	500	600
<b>Size of threaded rod for connection to ceiling</b>							
40	F	M10	1/2"	1/2"	1/2"	1/2"	1/2"
	G	M10	M10	M10	M10	M10	M10
50	F	M10	1/2"	1/2"	1/2"	1/2"	1/2"
	G	M10	M10	M10	M10	M10	M10
56	F	1/2"	1/2"	1/2"	1/2"	1/2"	1/2"
	G	M10	M10	M10	M10	M10	M10
63	F	1/2"	1/2"	1/2"	1/2"	1/2"	1/2"
	G	M10	M10	M10	M10	M10	M10
75	F	1/2"	1/2"	1/2"	1/2"	1/2"	1/2"
	G	M10	M10	M10	M10	M10	M10
90	F	1/2"	1/2"	1/2"	1/2"	3/4"	3/4"
	G	M10	M10	M10	M10	1/2"	1/2"
110	F	1/2"	1/2"	1/2"	3/4"	3/4"	3/4"
	G	M10	M10	M10	1/2"	1/2"	1/2"
125	F	1/2"	1/2"	3/4"	3/4"	3/4"	1"
	G	M10	M10	1/2"	1/2"	1/2"	1/2"
160	F	1/2"	1/2"	3/4"	1"	1"	1"
	G	M10	M10	1/2"	1/2"	1/2"	1/2"
200	F		3/4"	1"	1"	1"	1" 1/4
	G		1/2"	1/2"	1/2"	1/2"	1/2"
250	F		3/4"	1"	1"	1" 1/4	1" 1/4
	G		1/2"	1/2"	1/2"	1/2"	1/2"
315	F		3/4"	1"	1" 1/4	1" 1/4	1" 1/2
	G		1/2"	1/2"	1/2"	1/2"	3/4"

Note. Reductions and threaded rods greater than M10 can be obtained from the threading of standard steel pipes.

**Table 7.11** Wall installation (for HDPE).

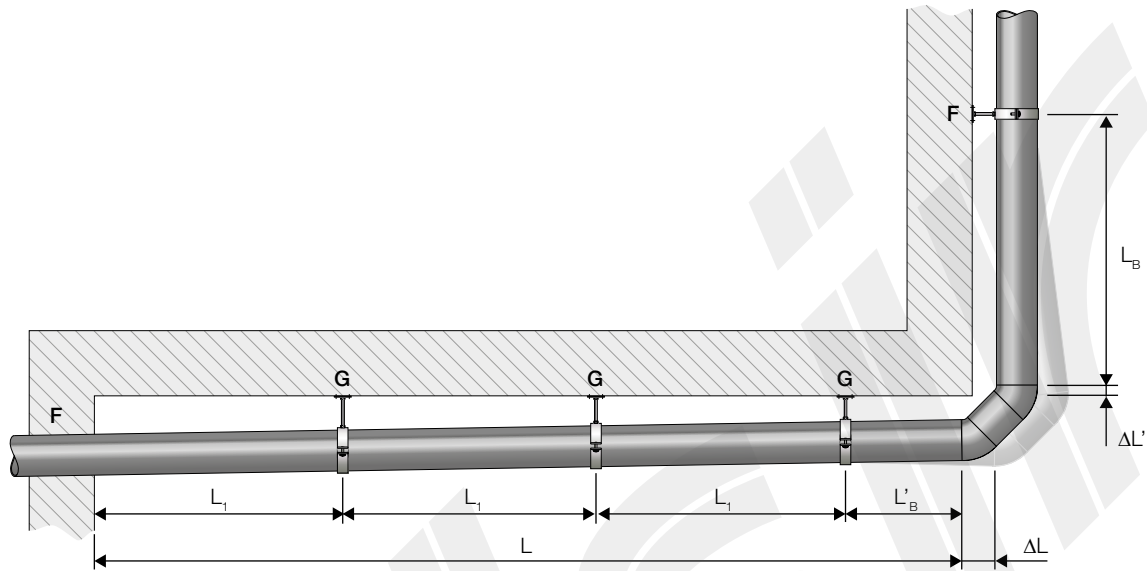
External diameter OD [mm]	Fixed point (F) or guide point (G)	Distance of the pipe axis from the wall L [mm]					
		100	200	300	400	500	600
		Size of the threaded rod for connection to the wall					
40	F	M10	1/2"	1/2"	1/2"	1/2"	1/2"
	G	M10	M10	M10	M10	M10	1/2"
50	F	1/2"	1/2"	1/2"	1/2"	1/2"	1/2"
	G	M10	M10	M10	M10	1/2"	1/2"
56	F	1/2"	1/2"	1/2"	1/2"	1/2"	1/2"
	G	M10	M10	M10	1/2"	1/2"	1/2"
63	F	1/2"	1/2"	1/2"	1/2"	1/2"	1/2"
	G	M10	M10	M10	1/2"	1/2"	1/2"
75	F	1/2"	1/2"	1/2"	1/2"	1/2"	3/4"
	G	M10	M10	1/2"	1/2"	1/2"	1/2"
90	F	1/2"	1/2"	1/2"	1/2"	3/4"	3/4"
	G	M10	1/2"	1/2"	1/2"	1/2"	1/2"
110	F	1/2"	1/2"	1/2"	3/4"	3/4"	1"
	G	M10	1/2"	1/2"	1/2"	1/2"	1/2"
125	F	1/2"	1/2"	3/4"	3/4"	1"	1"
	G	M10	1/2"	1/2"	1/2"	1/2"	1/2"
160	F	1/2"	3/4"	3/4"	1"	1"	1"
	G	M10	1/2"	1/2"	1/2"	1/2"	1/2"
200	F		3/4"	1"	1"	1" 1/4	1" 1/4
	G		1/2"	1/2"	1/2"	3/4"	3/4"
250	F		3/4"	1"	1" 1/4	1" 1/4	1" 1/4
	G		1/2"	1/2"	3/4"	3/4"	3/4"
315	F		3/4"	1"	1" 1/4	1" 1/2	1" 1/2
	G		1/2"	1/2"	3/4"	1"	1"

Note. Reductions and threaded rods greater than M10 can be obtained from the threading of standard steel pipes.

### A) Compensation with flexible arm (Type L)

This type of compensation avails of the changes of direction of the pipes; the segment of pipe (flexible arm) of length  $L_B$  accommodates the movement as a result of thermal expansion of a segment of pipe of length  $L$  perpendicular to it. In this case the correct distance of the pipe from the walls must be guaranteed to allow the compensation movement, it is therefore necessary to install the brackets according to the structure of the flexible arm. The distance between the brackets  $L_1$  is defined in Table 7.14.

Figure 7.50 Compensation with flexible arm Type L (for HDPE).

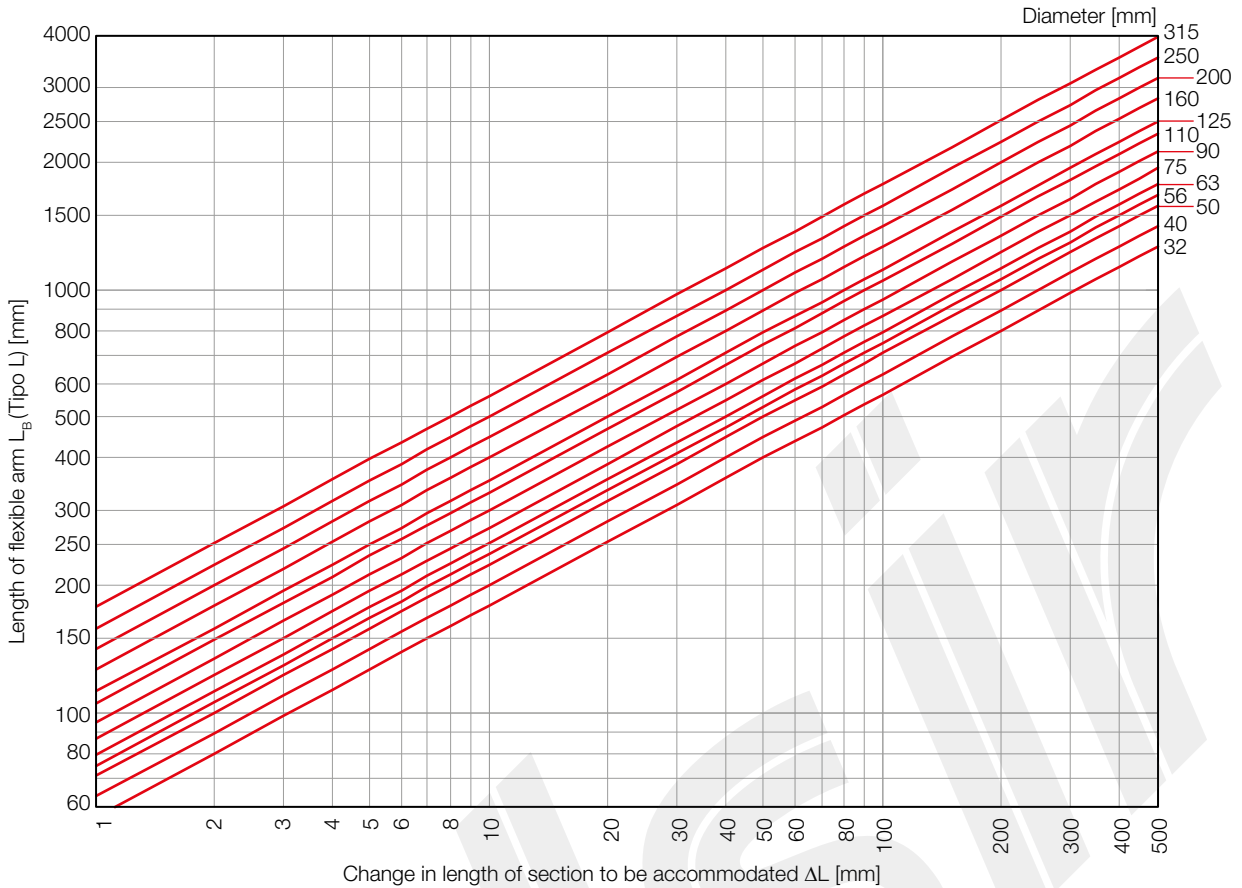


The length of the flexible arm  $L_B$  [mm] is calculated using the formula (represented also in the following diagram):

$$L_B = C \cdot \sqrt{OD \cdot \Delta L} \quad [7.7]$$

where  $C$  is the constant of the material, which for Valsir® HDPE pipe is 10,  $OD$  is the diameter of the pipe [mm] and  $\Delta L$  is the change in length of the segment of pipe to be accommodated.

**Figure 7.51** Calculation of compensation length using flexible arm Type L (for HDPE).



**Example 1.**

Calculate the length of the flexible arm of a Valsir® HDPE pipe with diameter 110 mm and length of 6 m installed at a temperature of 20°C and subjected to a maximum temperature of 70°C.

The thermal expansion of the section of pipe is:

$$\Delta L = \alpha \cdot L \cdot \Delta T = 0.2 \cdot 6 \cdot (70 - 20) = 60 \text{ mm} \quad [7.8]$$

and, using the formula or the diagram shown previously, the deviation arm  $L_b$  is calculated:

$$L_b = C \cdot \sqrt{OD \cdot \Delta L} = 10 \cdot \sqrt{(110 \cdot 60)} = 812 \text{ mm} \quad [7.9]$$

The same flexible arm is subjected to thermal expansion ( $L' = L_b$ ) of:

$$\Delta L' = \alpha \cdot L' \cdot \Delta T = 0.2 \cdot 0.812 \cdot (70 - 20) = 8.1 \text{ mm} \quad [7.10]$$

and requires therefore that part of the main pipe section is free to accommodate this expansion, the arm that is free to expand is:

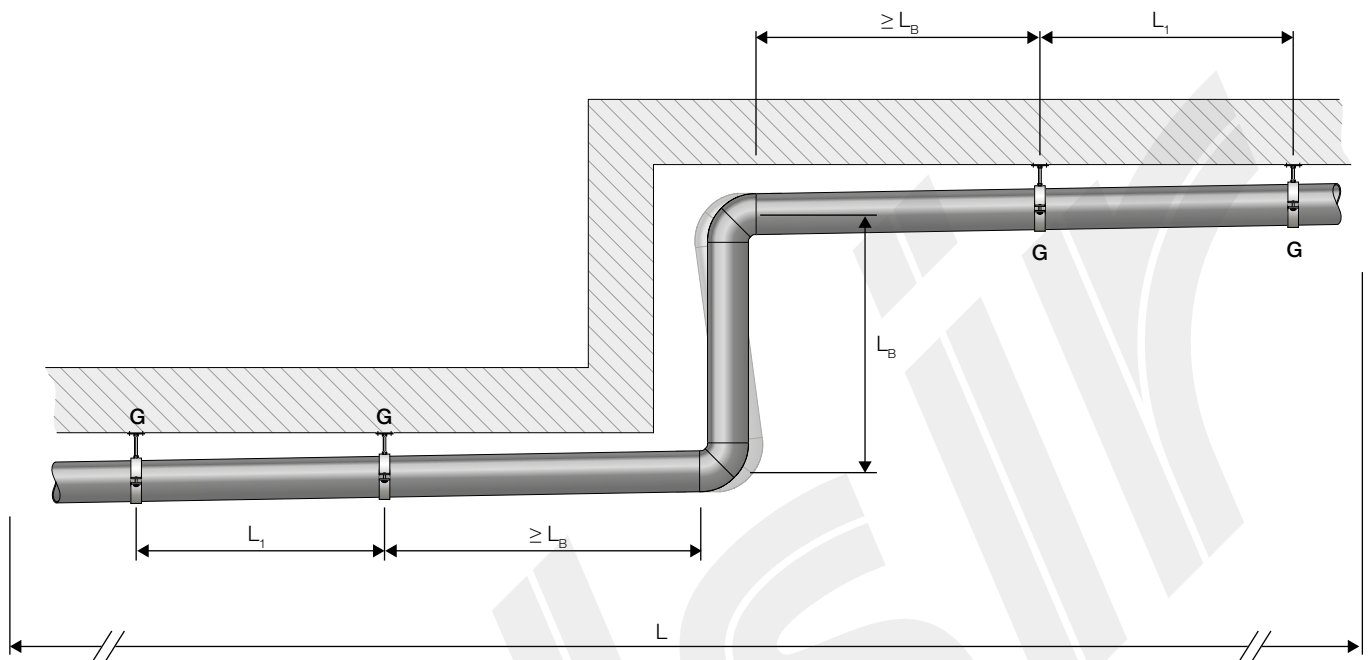
$$L_b' = C \cdot \sqrt{OD \cdot \Delta L'} = 10 \cdot \sqrt{(110 \cdot 8.1)} = 298 \text{ mm} \quad [7.11]$$

## B) Compensation using flexible arm disalignment (Type Z)

This type of compensation avails of a disalignment of the pipe; the section of pipe (flexible arm) of length  $L_B$  accommodates the expansions of the pipe of length  $L$  perpendicular to it.

The distance between the brackets  $L_1$  is defined in Table 7.14 shown previously whereas the distance between the flexible arm and the brackets must not be shorter than the length of the flexible arm  $L_B$ .

**Figure 7.52** Compensation using flexible arm disalignment Type Z (for HDPE).

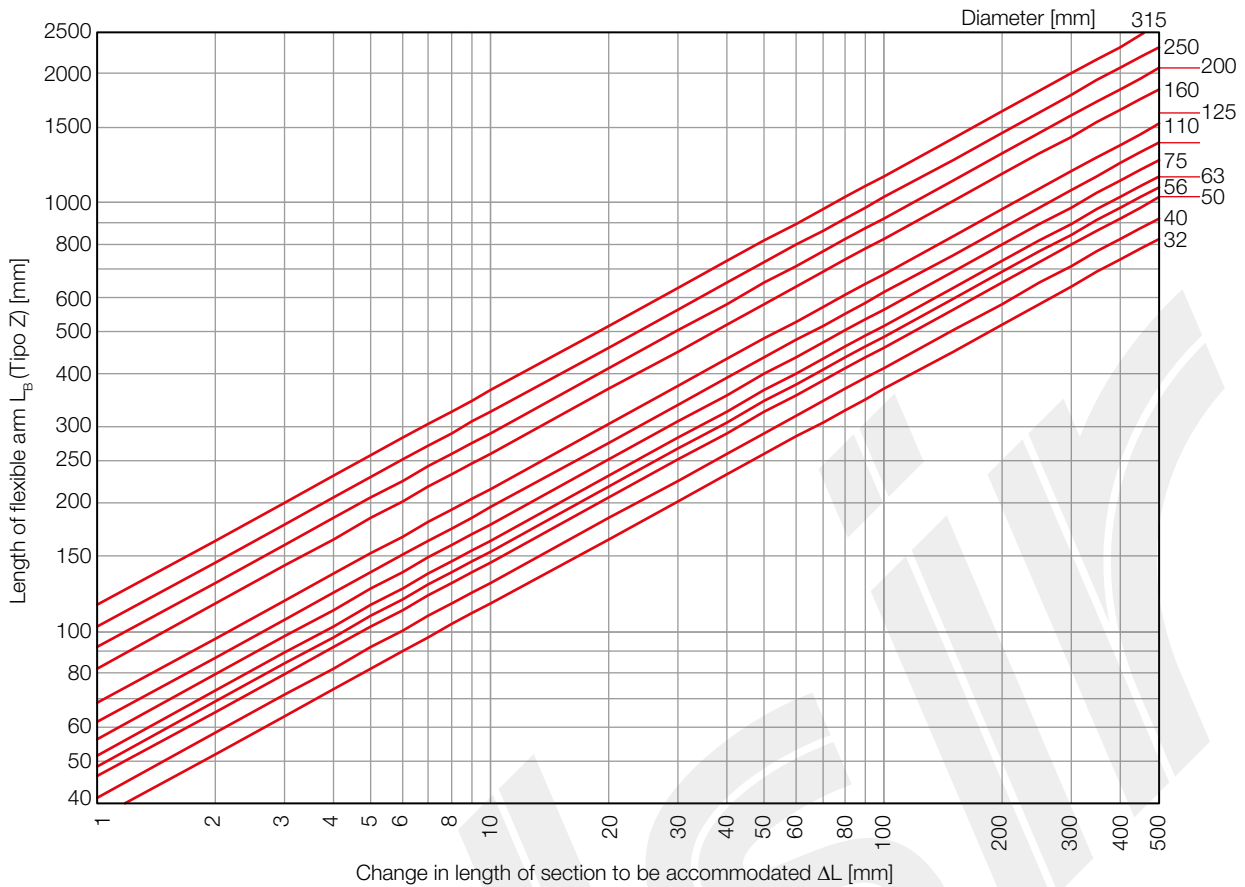


The length of the flexible arm  $L_B$  [mm] is calculated using the formula (also shown in the following diagram):

$$L_B = 0.65 \cdot C \cdot \sqrt{OD \cdot \Delta L} \quad [7.12]$$

Where  $C$  is the constant of the material, which for Valsir® HDPE pipes is 10,  $OD$  is the pipe diameter [mm] and  $\Delta L$  is the change in length of the segment of pipe to be compensated.

**Figure 7.53** Calculation of the compensation length using flexible arm disalignment Type Z (for HDPE).



**Example 2.**

Calculate the length of the flexible arm disalignment of a Valsir® HDPE pipe with a 63 mm diameter and a length of 40 m installed at a temperature of 10°C and subjected to a maximum temperature of 50°C.

The heat expansion of the section of pipe is:

$$\Delta L = \alpha \cdot L \cdot \Delta T = 0.2 \cdot 40 \cdot (50 - 10) = 320 \text{ mm} \quad [7.13]$$

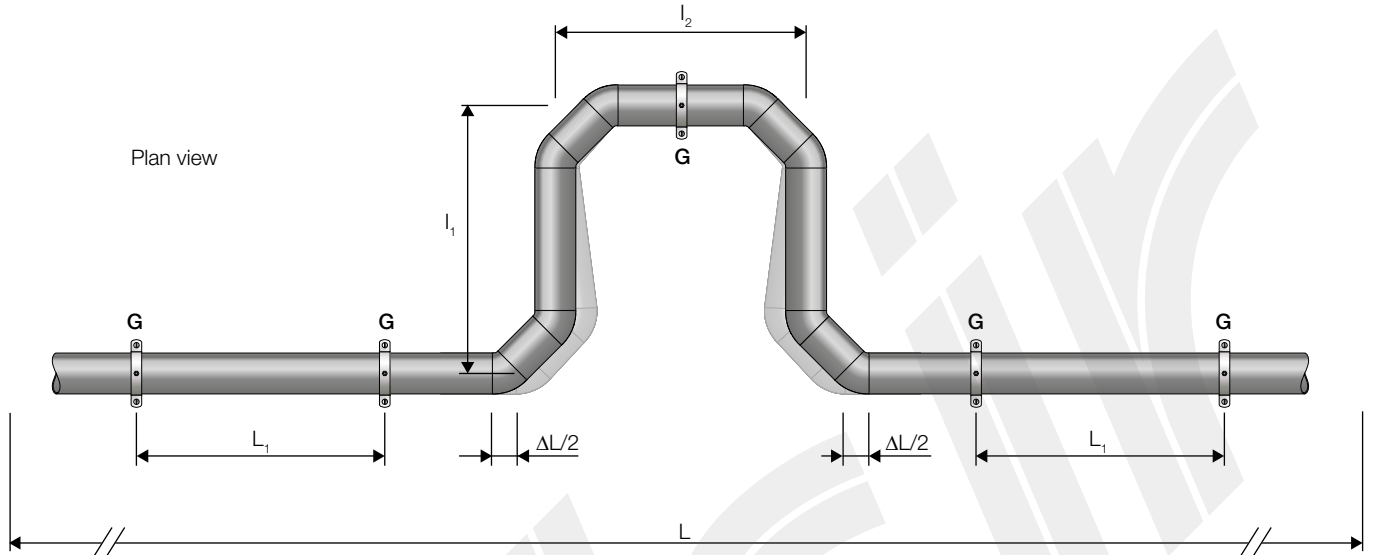
and, using the formula or the diagram shown previously, the deviation arm  $L_B$  is calculated:

$$L_B = 0.65 \cdot C \cdot \sqrt{(\text{OD} \cdot \Delta L)} = 0.65 \cdot 10 \cdot \sqrt{(63 \cdot 320)} = 922 \text{ mm} \quad [7.14]$$

### C) “Omega” compensation (U Type)

This type of compensation is generally employed in cellar collectors when the expansions cannot be accommodated by changes in direction of the pipes. Whereas in the case of deviation arm compensation, changes in direction of the system are used, in this case the configuration must be created especially. The distance between the brackets  $L_1$  is defined in Table 7.14 shown previously. This configuration cannot be used on vertical walls.

**Figure 7.54** “Omega” compensation Type U (for HDPE).



The total length of the “omega” compensation  $L_B$  [mm] is calculated using the formula (also shown in the following diagram):

$$L_B = 2 \cdot l_1 + l_2 = C \cdot \sqrt{OD \cdot \Delta L} \quad [7.15]$$

where C is the material constant, which for the Valsir HDPE pipes is 10, OD is the pipe diameter [mm],  $\Delta L$  is the change in length of the pipe section to be compensated,  $l_1$  and  $l_2$  are the sides of the “omega” compensation.

The “omega” compensation must be configured depending on the available spaces, however, where possible, it is recommended to maintain the following dimensional ratio:

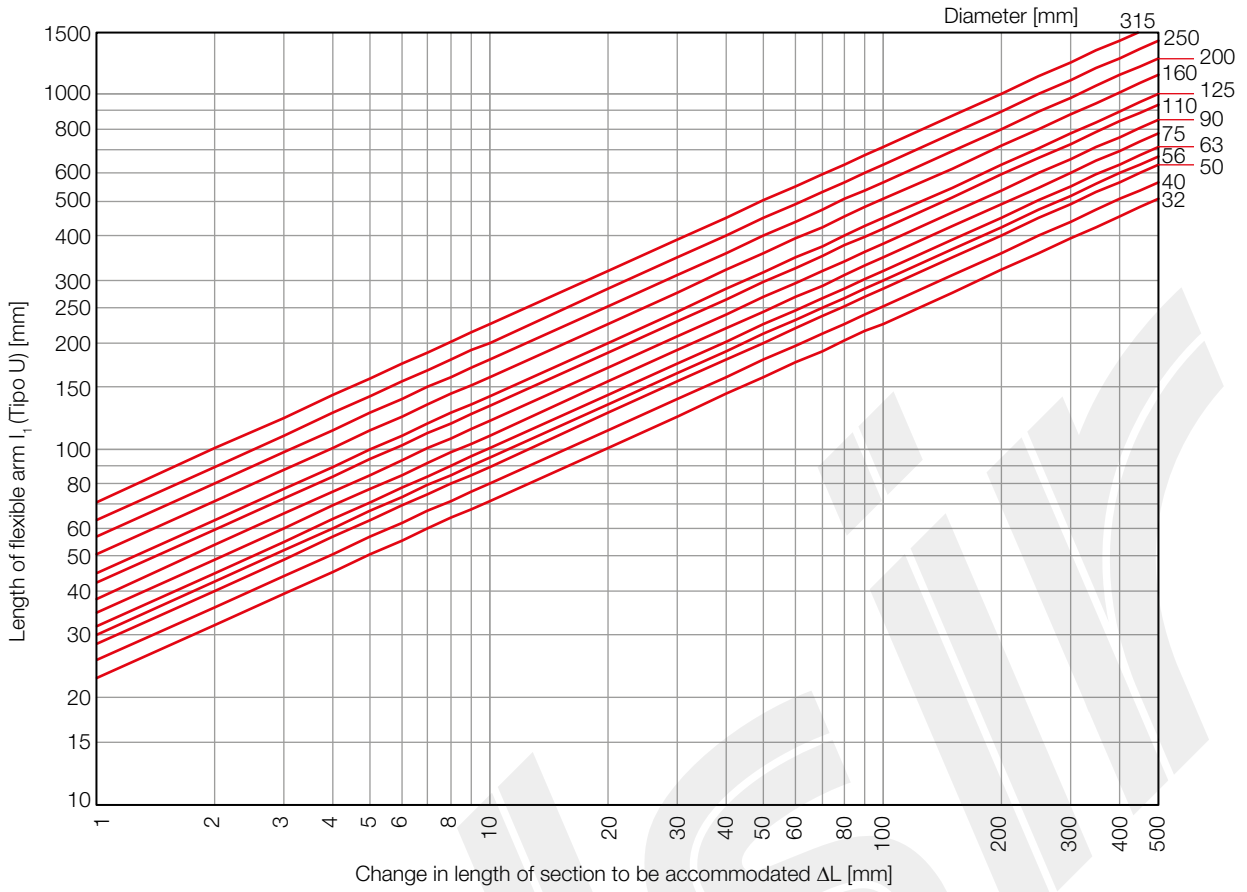
$$l_1 = 2 \cdot l_2 \quad [7.16]$$

and therefore:

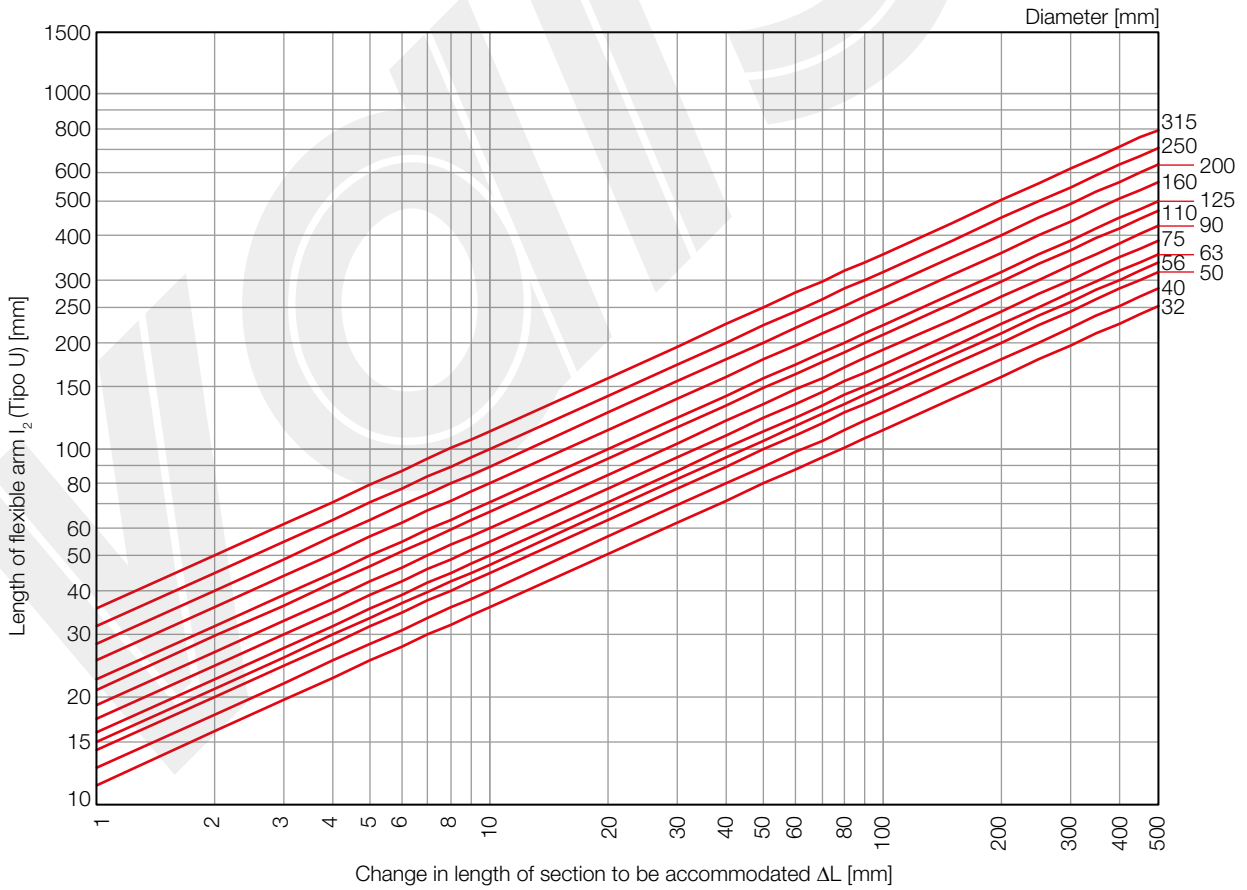
$$l_1 = 0.4 \cdot L_B \quad [7.17]$$

$$l_2 = 0.2 \cdot L_B$$

**Figure 7.55** Calculation of the length of the arm  $l_1$  of the “omega” Type U (for HDPE).



**Figure 7.56** Calculation of the length of arm  $l_2$  of the “omega” Type U (for HDPE).



**Example 3.**

Calculate the expansion “omega” for the Valsir® HDPE pipe section of diameter 90 mm and length of 35 m installed at a temperature of 15°C and subjected to a maximum temperature of 65°C.

The thermal expansion of the pipe section is:

$$\Delta L = \alpha \cdot L \cdot \Delta T = 0.2 \cdot 35 \cdot (65 - 15) = 350 \text{ mm} \quad [7.18]$$

and, using the formula or the diagram seen previously, the total length is calculated for the “omega”  $L_B$ :

$$L_B = C \cdot \sqrt{(OD \cdot \Delta L)} = 10 \cdot \sqrt{(90 \cdot 350)} = 1775 \text{ mm} \quad [7.19]$$

and considering the dimensional ratio suggested:

$$l_1 = 0.4 \cdot L_B = 0.4 \cdot 1775 = 710 \text{ mm} \quad [7.20]$$

$$l_2 = 0.2 \cdot L_B = 0.2 \cdot 1775 = 355 \text{ mm}$$

## 7.2.6 Exposed installation: rigid bracketing

Rigid installation using fixed point brackets is employed in the Valsir® HDPE waste system when it is installed with welded joints (without using expansion sockets or push-fit sockets). It uses the deviation resistance of the bracket to absorb the forces that are generated due to the changes in length.

For this type of installation, brackets must be used that resist the high thrust forces that are discharged, through the anchor screws, to the building structure. The following indications are applied for conventional waste systems and not for syphonic rainwater systems (Rainplus®).

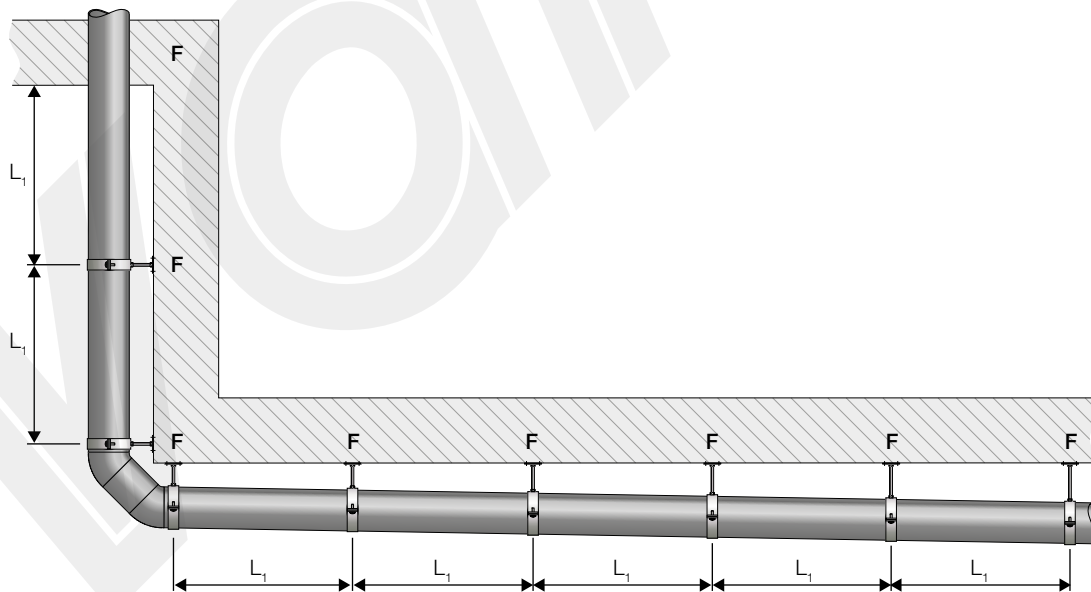
The maximum intervals to be adopted for the brackets are indicated in the following table.

**Table 7.12** Maximum bracketing intervals for rigid systems (for HDPE).

External diameter OD [mm]	Bracketing interval $L_1$ [m]
32	0.8
40	0.8
50	0.8
56	0.8
63	0.8
75	0.8
90	0.9
110	1.1
125	1.3
160	1.6
200	2.0
250	2.0
315	2.0

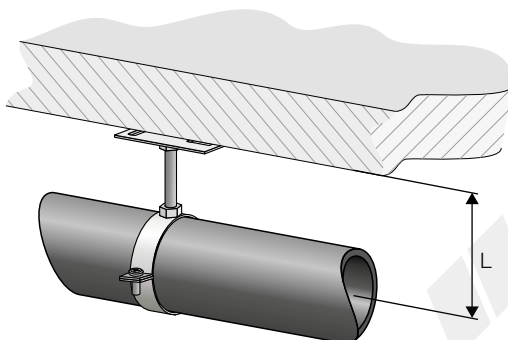
Note. The intervals are valid both for horizontal and vertical pipes and are calculated as  $10 \cdot OD$  with a minimum of 0.8 m and a maximum of 2 m.

**Figure 7.57** Rigid installation using fixed point brackets (for HDPE).



- To choose the threaded rod to connect the bracket to the wall or ceiling, refer to the following table. The size of the threaded rod depends on the forces caused by the weight of the pipe, the weight of the waste water and therefore in relation to the diameter of the pipe and the distance from the building structure and the forces caused by the thermal expansion.

**Figure 7.58** Distance of ceiling or wall installation (for HDPE).



**Table 7.13** Ceiling or wall installation (for HDPE).

External diameter OD [mm]	Distance of the pipe axis from the ceiling L [mm]	
	100	200
	<b>Size of the threaded rod for connection to the ceiling</b>	
40	1/2"	1/2"
50	1/2"	1/2"
56	1/2"	1/2"
63	1/2"	1/2"
75	1/2"	3/4"
90	1/2"	3/4"
110	1/2"	3/4"
125	1/2"	1"
160	1/2"	1"
200		1"
250		1"
315		1"

Note. Reductions and threaded rods greater than M10 can be obtained from the threading of standard steel pipes.

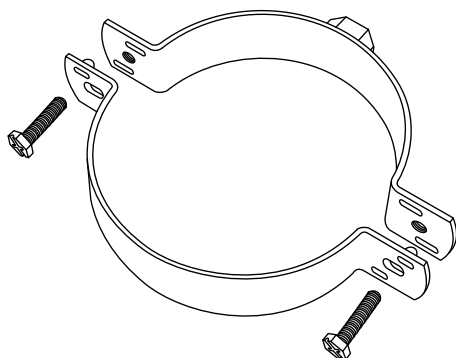
## 7.2.7 Installation of brackets

### 7.2.7.1 Guide point with bracket without anti-vibration rubber

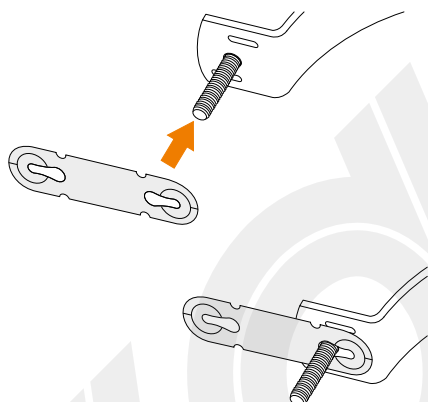


Watch the video on website:  
[valsir.it/u/collarepuntoscorrevole](https://valsir.it/u/collarepuntoscorrevole)

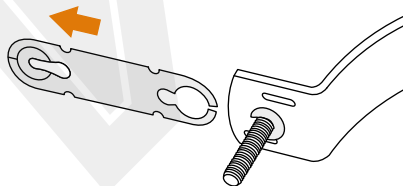
#### Installation indications



- 1) The bracket used for the creation of guide points is the same as the bracket used for creating fixed points. By turning the two parts of the bracket by 180° the cambers on the lower part of the bracket don't coincide with the slots on the upper part of the bracket thus guaranteeing the partial closure of the bracket.



- 2) The screws can be prevented from coming out of the bracket housing by using the special plastic bands contained in the package. Insert the screw into the widest hole of the two slots of the plastic band to full insertion depth.

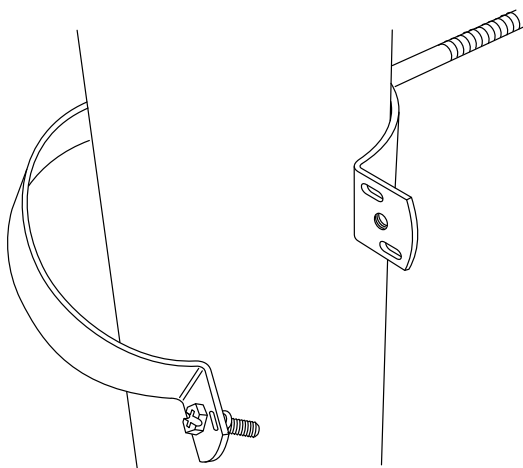


- 3) Pull the plastic band firmly; the pre-cut ring on the plastic band will remain anchored to the screw thus preventing it from coming out of the bracket during the installation phases.

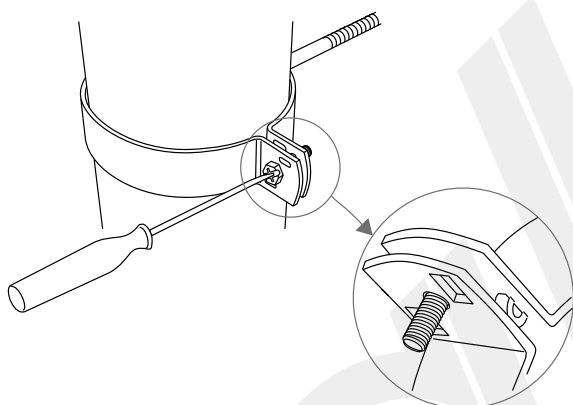
---

## Installation indications

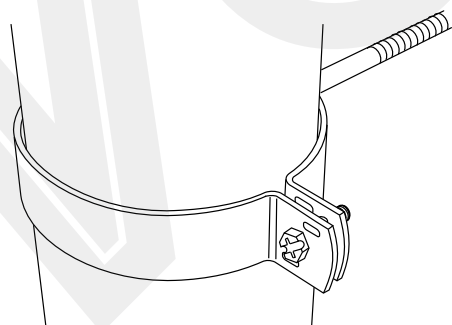
---



- 4) Install the bracket on the wall or ceiling and position the pipe in compliance with the rules already defined in this section.



- 5) Tighten the screws of the bracket in such a way that the cambers on the lower part of the bracket are alternated compared with the slots on the upper part of the bracket.



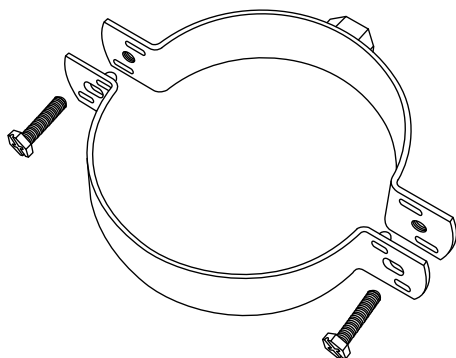
- 6) With such a configuration the internal diameter of the bracket is greater than the external diameter of the pipe to create a guide point bracket.

## 7.2.7.2 Fixed point with bracket without anti-vibration rubber

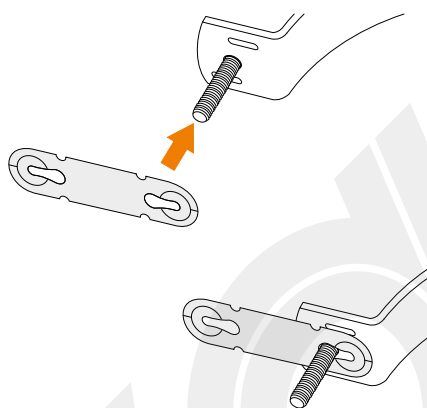


Watch the video on website:  
[valsir.it/u/collarepuntofisso](https://valsir.it/u/collarepuntofisso)

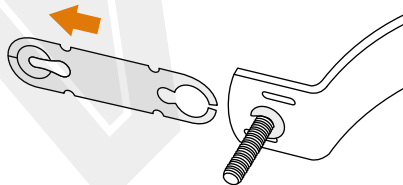
### Installation indications



- 1) The bracket used for the creation of fixed points is the same as the bracket used for creating guide points. By turning the two parts of the bracket by 180° the cambers on the lower part of the bracket coincide with the slots on the upper part of the bracket thus guaranteeing the total closure of the bracket.



- 2) The screws can be prevented from coming out of the bracket housing by using the special plastic bands contained in the package. Insert the screw into the widest hole of the two slots of the plastic band to full insertion depth.

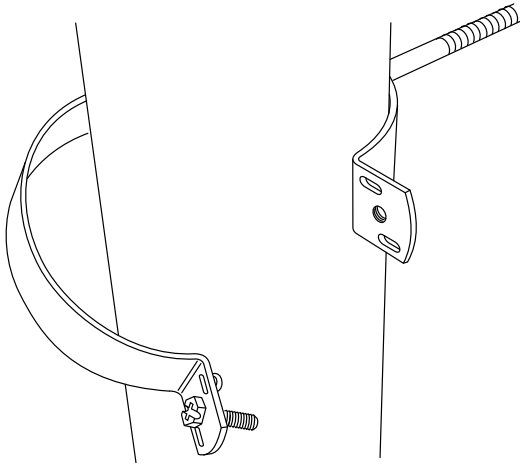


- 3) Pull the plastic band firmly; the pre-cut ring on the plastic band will remain anchored to the screw thus preventing it from coming out of the bracket during the installation phases.

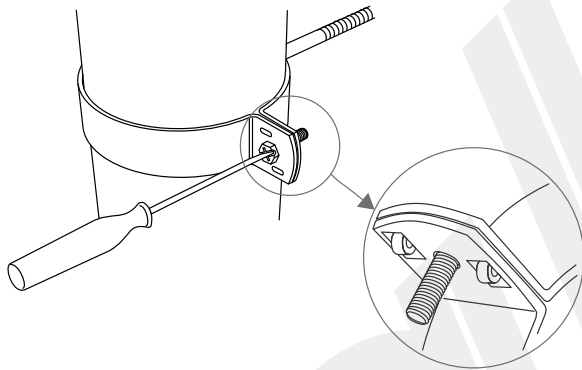
---

## Installation indications

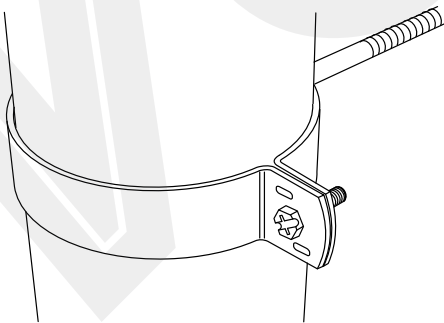
---



- 4) Install the bracket on the wall or ceiling and position the pipe in compliance with the rules already defined in this section.



- 5) Tighten the bracket screws making sure that the cambers on the lower part of the bracket coincide with the slots on the upper part of the bracket.



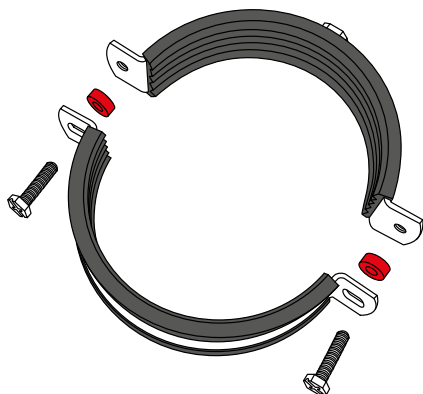
- 6) With this configuration the internal diameter of the bracket is smaller than the external diameter of the pipe and a fixed point bracket has been created.

### 7.2.7.3 Guide point with bracket with anti-vibration rubber

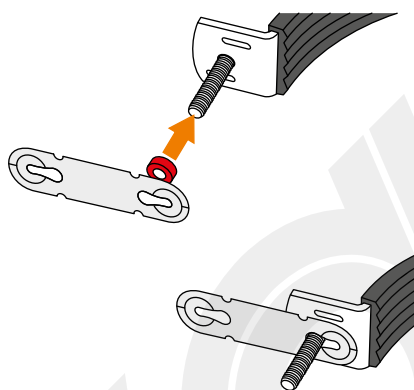


Watch the video on website:  
[valsir.it/u/collareantivibrantepuntoscorrevole](https://valsir.it/u/collareantivibrantepuntoscorrevole)

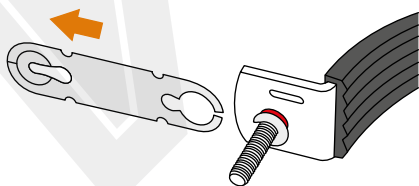
#### Installation indications



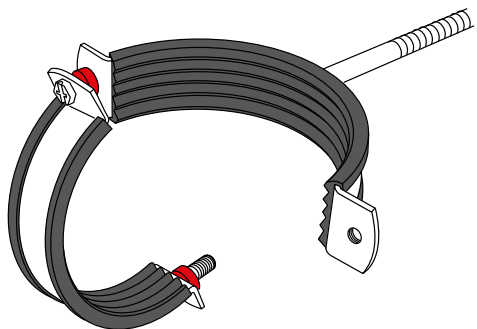
- 1) The bracket used to create a guide point is the same as the bracket employed to create a fixed point. By using the coloured spacers that are included in the package a certain distance is maintained between the two parts of the bracket allowing a partial closure on the pipe.



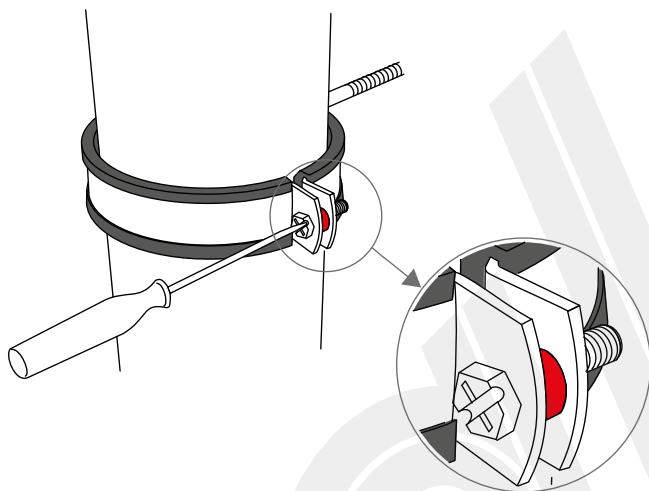
- 2) The screws can be prevented from coming out of the bracket housing by using the special plastic bands contained in the package. Insert the screw into the widest hole of the two slots of the plastic band to full insertion depth.



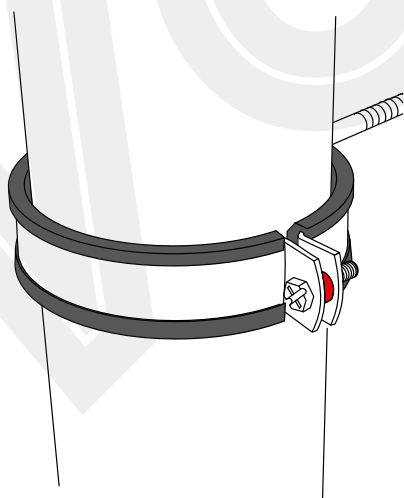
- 3) Pull the plastic band firmly; the pre-cut ring on the plastic band will remain anchored to the screw thus preventing it from coming out of the bracket during the installation phases.



- 4) Install the bracket on the wall or ceiling and position the pipe in compliance with the rules already defined in this section.



- 5) Tighten the screws of the bracket.



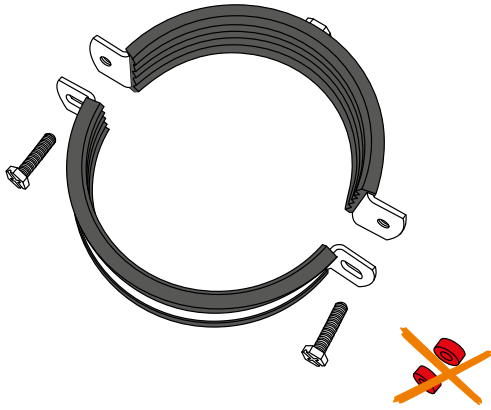
- 6) With such a configuration the internal diameter of the bracket is greater than the external diameter of the pipe thus creating a guide point bracket.

#### 7.2.7.4 Fixed point with bracket with anti-vibration rubber

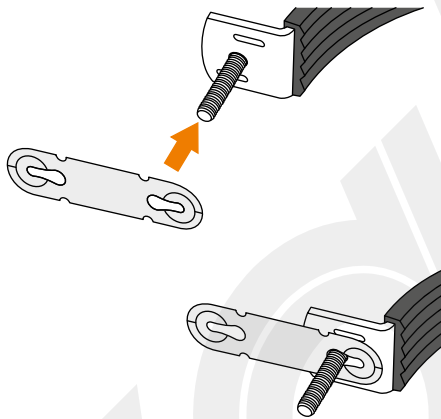


Watch the video on website:  
[valsir.it/u/collareantivibrantepuntofisso](https://valsir.it/u/collareantivibrantepuntofisso)

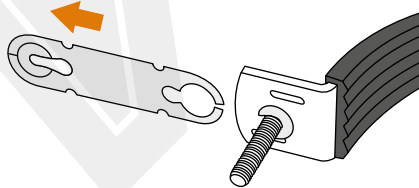
#### Installation indications



- 1) The bracket used to create a fixed point is the same as the bracket employed to create a guide point. By not using the coloured spacers included in the package the total closure of the two bracket parts is guaranteed allowing complete closure on the pipe.



- 2) The screws can be prevented from coming out of the bracket housing by using the special plastic bands contained in the package. Insert the screw into the widest hole of the two slots of the plastic band to full insertion depth.

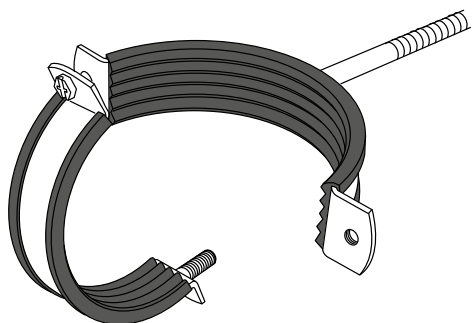


- 3) Pull the plastic band firmly; the pre-cut ring on the plastic band will remain anchored to the screw thus preventing it from coming out of the bracket during the installation phases.

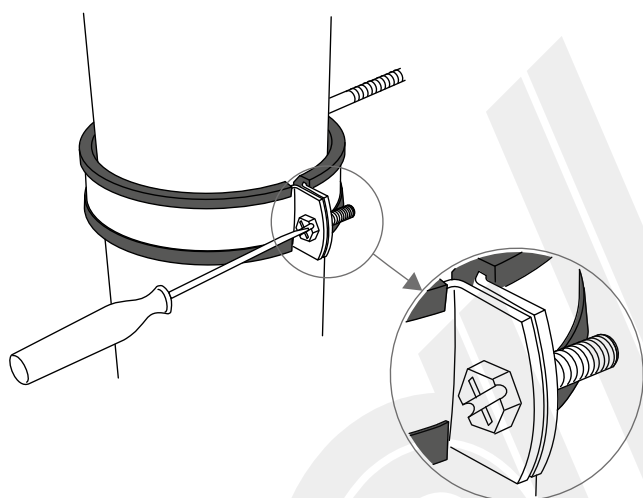
---

## Installation indications

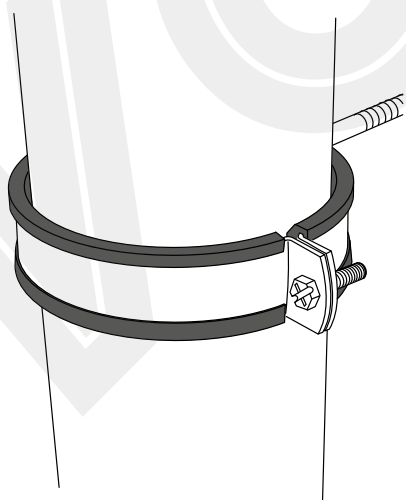
---



- 4) Install the bracket on the wall or ceiling and position the pipe in compliance with the rules already defined in this section.



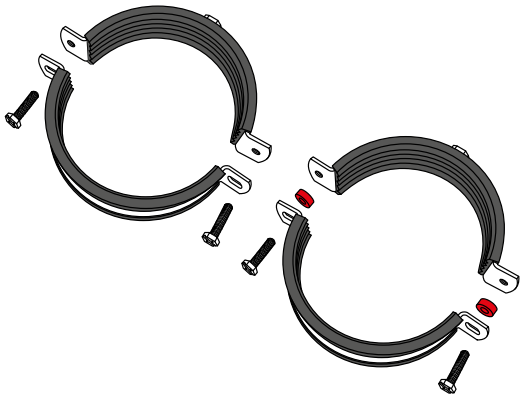
- 5) Tighten the screws of the bracket.



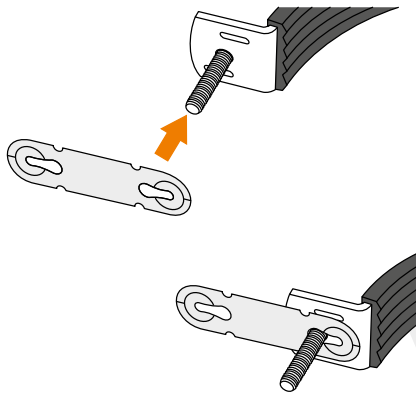
- 6) With this configuration the internal diameter of the bracket is smaller than the external diameter of the pipe and a fixed point bracket has been created.

## 7.2.7.5 Sound reducing fixed points

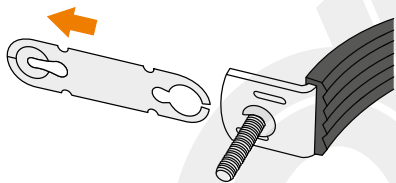
### Installation indications



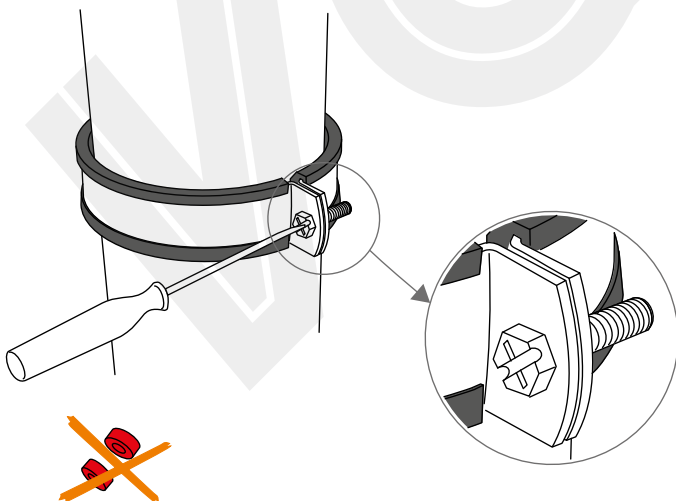
- 1) To create sound reducing fixed points it is necessary to use two identical brackets with anti vibration rubber.



- 2) The screws can be prevented from coming out of the bracket housing by using the special plastic bands contained in the package. Insert the screw into the widest hole of the two slots of the plastic band to full insertion depth.

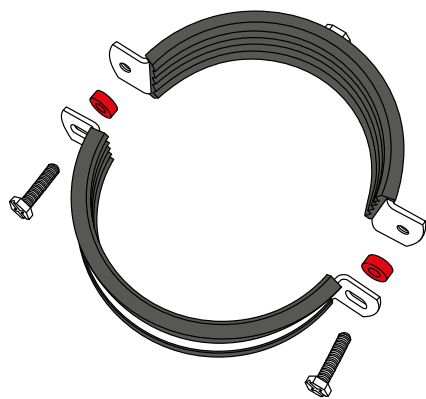


- 3) Pull the plastic band firmly; the pre-cut ring on the plastic band will remain anchored to the screw thus preventing it from coming out of the bracket during the installation phases.

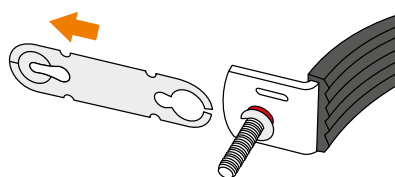


- 4) Position the first bracket on the pipe and tighten, eliminating the coloured spacers.

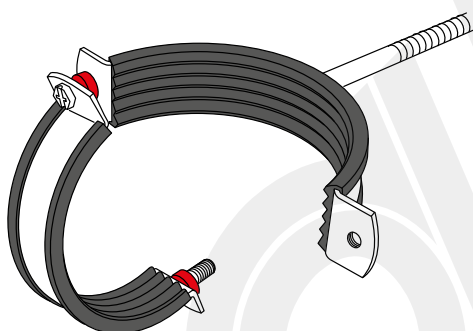
## Installation indications



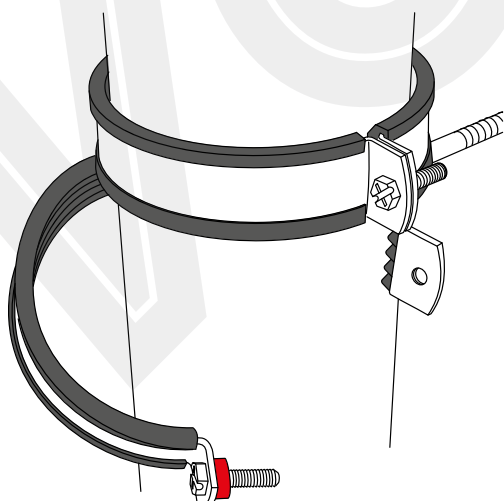
- 5) The second bracket, on the other hand, must be used with the coloured spacers.



- 6) As with the first bracket, the screws and spacers can be prevented from coming out of the bracket housing by using the special plastic bands contained in the package.



- 7) Fit the second bracket to the wall following the rules indicated previously in this chapter. Remember that this type of installation is performed exclusively on the wall and not on the ceiling.

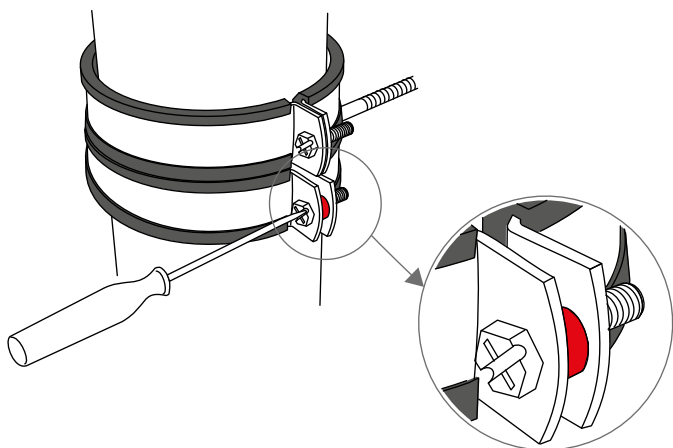


- 8) Position the pipe in such a way that the first bracket (the one without the coloured spacers) is placed over the bracket that has already been anchored to the wall. Support the pipe until the second bracket has been closed.

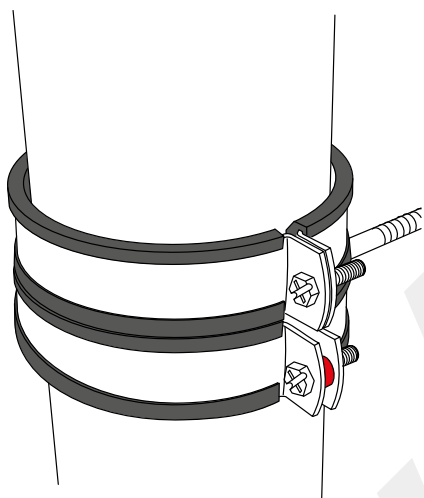
---

## Installation indications

---



- 9) Tighten the screws of the second bracket.



- 10) Release the pipe in such a way that the top bracket transfers the weight of the pipe to the bracket below and contact is with the anti-vibration rubber only. Make sure that the pipe is perfectly vertical and that it is positioned at the centre of the lower bracket.

**Valsir** was founded in 1987, on the basis of a precise industrial strategy adopted by the Fondital Group - a holding that is leader in the plumbing and heating market with a sales turnover of over 900 million Euro and 2,600 employees - with factories in Italy, in Valsabbia to the north of Brescia and abroad in Portugal, Poland, Russia, Romania, the Ukraine, France and South Africa.

Valsir is today a solid and expanding firm within a group whose true points of cohesion and strength lie within a strong sense of collaboration and the contribution of specific professional skills of each single component.

The head and heart of Valsir are in Vestone, in Valsabbia, on the route which leads from Lake Garda to the Brenta Dolomites.

It is here that the strategies of this globally oriented company are defined, involving business agreements and joint-ventures in Europe, Asia and Africa.

Economic growth, technological development, pursuit of quality, on-going research, project design activities, the strong presence in European markets and in the rest of the world are the elements that have guided and still guide Valsir policies today.

- WASTE SYSTEMS 
- SUPPLY SYSTEMS 
- GAS SYSTEMS 
- FLUSHING SYSTEMS 
- BATHROOM SYSTEMS 
- TRAPS 
- RADIANT SYSTEMS 
- DRAINAGE SYSTEMS 
- ACADEMY 

Value: 87,00 €



**VALSIR S.p.A.**  
 Località Merlaro, 2  
 25078 Vestone (BS) - Italy  
 Tel. +39 0365 877.011  
 Fax +39 0365 81.268  
 e-mail: valsir@valsir.it  
[www.valsir.it](http://www.valsir.it)

