

### TE

#### Function



Thermoelectric heads function by exploiting the expansion of a thermosensitive element, which is heated up through an electrical resistor when the valve needs to be opened. This allows for a slow open/close cycle and protects the system against water hammer. Thermoelectric heads can only be connected to on/off thermostats or chrono-thermostats. Do not use 3-point or modulating thermostats or chrono-thermostats.

All TE thermoelectric heads are of the normally closed type. This means they only open when an opening input (voltage) comes from the control sensor (ex. thermostat). This allow the head to work only when there is a need for hot or cold water to flow through the heating body, and to remain idle for the rest of the time.

The new thermoelectric heads can be installed in any position, even upside down, since they are secured against leakage from the thermostatic screws.

#### Technical data

	TE 3110	TE 3111	TE 3112	TE 3113
Supply voltage:	230 V AC, +10%..-10%,50/60Hz	24 V AC/DC, -10%..+20%, 0-60Hz	230 V AC, +10%..-10%,50/60Hz	24 V AC/DC, +20%..-10%,50/60Hz
Max input current:	300 mA for max 200 ms	250 mA for max 2 min	300 mA for max 200 ms	250 mA for max 2 min
Operating power:	2 W	2 W	1.8 W	1.8 W
Stroke:	4 mm	4 mm	4 mm	4 mm
Actuating force:	100 N +10%	100 N +10%	90 N ± 5%	90 N ± 5%
Micro-switch voltage:	-	-	230 V AC: resistive load 5 A, inductive load 1 A	24 V AC/DC: ohmic load 3 A, inductive load 1 A
Micro-switch trigger point:	-	-	Ca. 3 mm	Ca. 3 mm
Fluid temperature:	0÷100 °C	0÷100 °C	0÷100 °C	0÷100 °C
Storage temperature:	-25÷60 °C	-25÷60 °C	-25÷60 °C	-25÷60 °C
Room temperature:	0÷60 °C	0÷60 °C	0÷60 °C	0÷60 °C
Degree of protection:	IP 54	IP 54	IP 54	IP 54
Protection class:	II	III	II	III
CE conformity:	EN 60730	EN 60730	EN 60730	EN 60730
Connecting cables:	2x0.75 mm <sup>2</sup> PVC	2x0.75 mm <sup>2</sup> PVC	4x0.75 mm <sup>2</sup> PVC	4x0.75 mm <sup>2</sup> PVC
Length of cables:	1 m	1 m	1 m	1 m
Weight:	100 g	100 g	Ca. 155 g	Ca. 155 g
Overvoltage resistance according to EN 60730-1:	2.5 kV	1 kV	2.5 kV	1 kV

#### Materials

Housing:	Polyamide
Housing colour:	Grey
Cable colour:	Grey

**Dimensional Drawings**

**TE 3110**

Thermoelectric head 230 V (normally closed – opens with voltage)

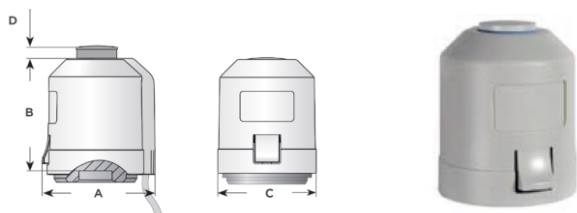

Code	Size	A	B	C	D	F
69011021	M30x1.5	50	54	44	5.5	M30x1.5

**TE 3111**

Thermoelectric head 24 V (normally closed – opens with voltage)

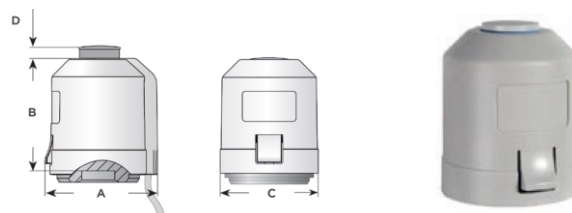

Code	Size	A	B	C	D	F
69011022	M30x1.5	50	54	44	5.5	M30x1.5

**TE 3112**

Thermoelectric head 230 V with limit switch (normally closed – opens with voltage)

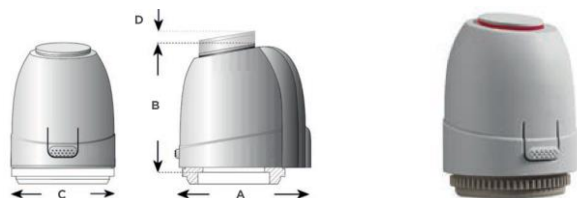

Code	Size	A	B	C	D	F
69011026	M30x1.5	56	54	44	4	M30x1.5

**TE 3113**

Thermoelectric head 230 V with limit switch (normally closed – opens with voltage)

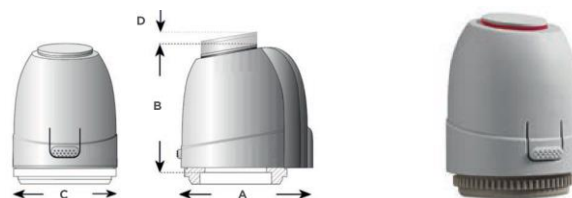

Code	Size	A	B	C	D	F
69011027	M30x1.5	56	54	44	4	M30x1.5

## Characteristic Curves

### TE 3110 – TE 3111

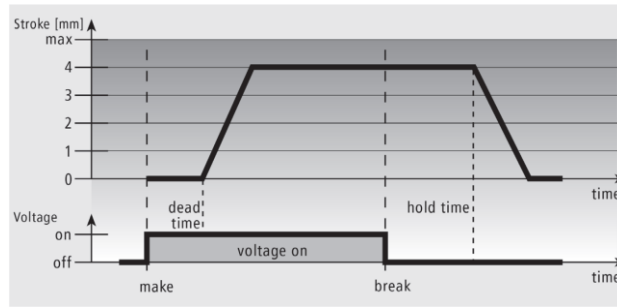

### TE 3112 – TE 3113

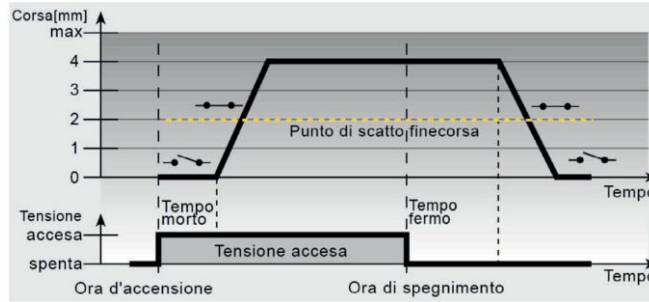

## Working Instructions

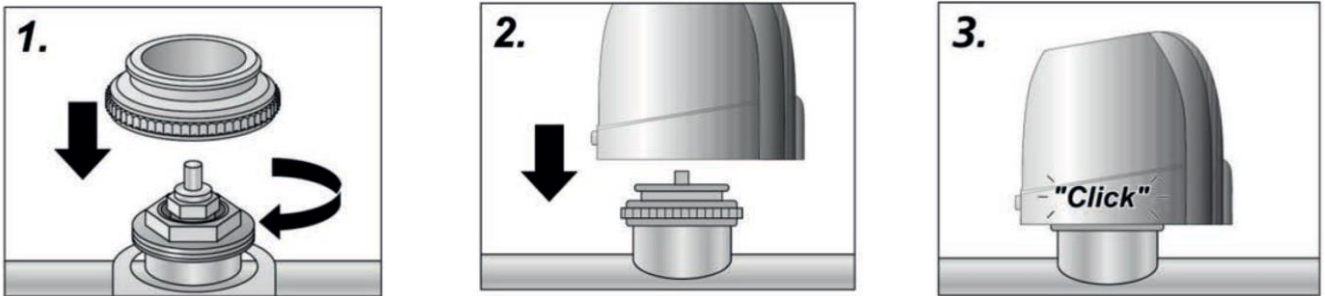

## How to install thermoelectric heads

- Screw the adapter to the valve by hand;
- Place the actuator into the adapter by hand, in a vertical position;
- The actuator is easily fitted into the adapter with a slight vertical hand pressure; a clicking sound can be heard.

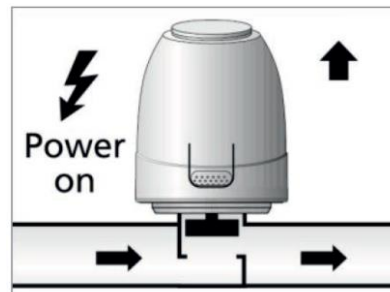
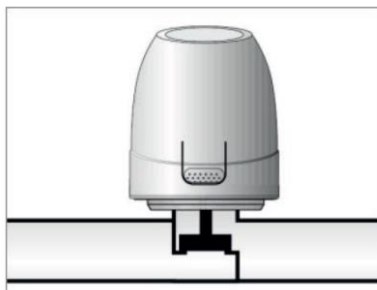

## Function indicator

The function indicator (round light blue diskette) allows to easily see (or feel, if in the dark) if the valve is open or closed. The indicator pops up when the valve opens.

## Start-up of thermoelectric heads

All thermoelectric heads are supplied in a locked, partially opened position (ca. 1/4).

In order to unlock and start up, the head must be fed power for at least 6 minutes (for example from the thermostat in heating position). During this time, the head opens completely and breaks the block.

After that, the head is ready to function.

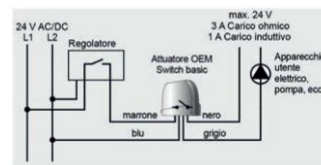
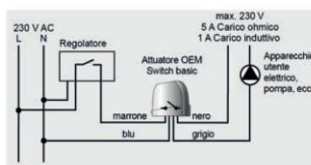
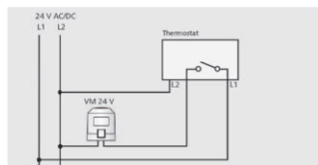
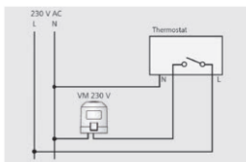

### Thermoelectric head

ART. TE 3110

COD. 69011021

Thermoelectric head 230 V, normally closed, without limit switch.

Colour of the connecting cables of the thermoelectric head without limit switch and corresponding function.

### Thermoelectric head

ART. TE 3111

COD. 69011022

Thermoelectric head 24 V, normally closed, without limit switch.

Colour of the connecting cables of the thermoelectric head without limit switch and corresponding function.

### Thermoelectric head

ART. TE 3112

COD. 69011026

Thermoelectric head 230 V, normally closed, with limit switch.

Colour of the connecting cables of the thermoelectric head without limit switch and corresponding function.

### Thermoelectric head

ART. TE 3113

COD. 69011027

Thermoelectric head 24 V, normally closed, with limit switch.

Colour of the connecting cables of the thermoelectric head without limit switch and corresponding function.

Cable colour	Description	Cable colour	Description	Cable colour	Description	Cable colour	Description
Brown	Cable connecting head to voltage	Brown	Cable connecting head to voltage	Brown	Cable connecting head to voltage	Brown	Cable connecting head to voltage
Blue	Cable connecting head to neutral	Blue	Cable connecting head to neutral	Blue	Cable connecting head to neutral	Blue	Cable connecting head to neutral
				Black and grey	Limit switch output cables	Black and grey	Limit switch output cables

### Connections for thermoelectric heads

The thermostat and/or chrono-thermostat output to which the thermoelectric heads must be connected are generally as shown in the following wiring diagrams:



Where:

**C:** connection for power supply cable.

**N.C.:** output normally closed for cable from the thermoelectric head (not to be used since our thermoelectric head is normally closed).

**N.A.:** output normally open for the connection cable coming from the thermoelectric head (the brown electric cable coming from the thermostatic head must be connected to this type of output).

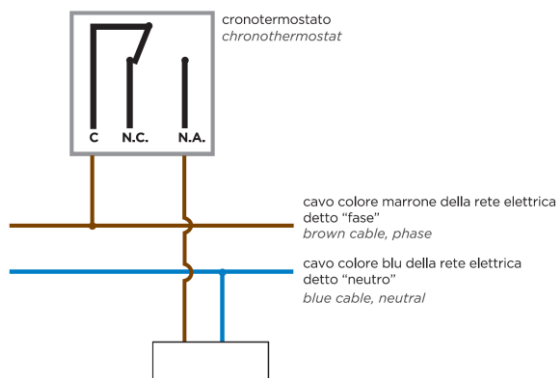

### Example of application with connections

- 1 chrono-thermostat
- 1 thermoelectric head

Each thermostat or chrono-thermostat can normally fit up to 10 thermoelectric heads in parallel. To know exactly the number of heads which can be connected, divide the thermostat output contact value N.A. by the head starting power.

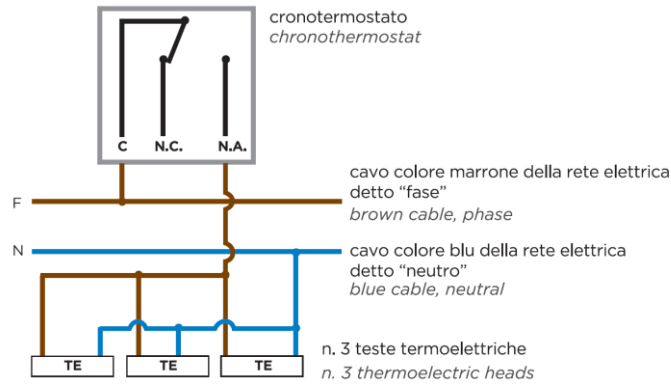

### Example of application with connections

- 1 chrono-thermostat
- 3 thermoelectric heads connected in parallel

### Thermoelectric heads with auxiliary or limit switch contact

The limit switch contact is used to start the heating system pump when there is at least one thermoelectric head functioning, hence the pump cannot function when all the thermostatic valves are closed. This device, stopping the pump when the system is not working, reduces wear on the pump and noise caused by the cavitation.

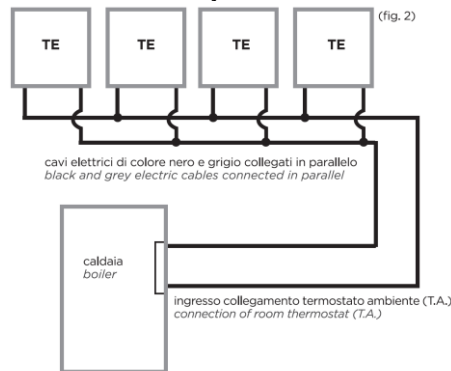

Connection of thermoelectric heads with limit switch contact and boiler with "room thermostat".

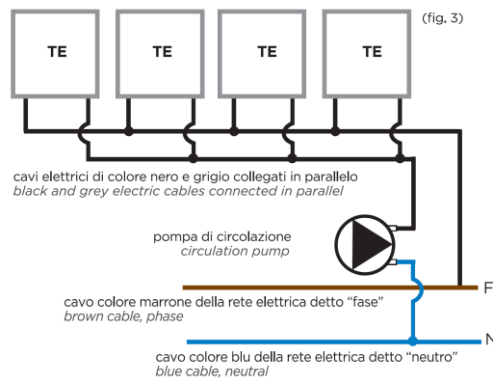

Connection of thermoelectric heads with limit switch contact and circulation pump for heating systems.

## Item Specifications

---

### TE 3110

Electrothermic actuator, normally closed, with indicator of position. Clip mount on adapter with M30x1.5 thread. Supply voltage 230 V AC. Starting current 300 mA. Running current 8 mA. Working power 2 W. Degree of protection IP 54. Protection class II. May be installed horizontally, vertically and upside down. Body in grey PA. Max. room temperature 60 °C. Opening/closing time ca. 3 min. Length of cable 1 m. CE conformity: EN 60730.

---

### TE 3111

Electrothermic actuator, normally closed, with indicator of position. Clip mount on adapter with M30x1.5 thread. Supply voltage 24 V AC. Starting current 250 mA. Running current 75 mA. Working power 2 W. Degree of protection IP 54. Protection class III. May be installed horizontally, vertically and upside down. Body in grey PA. Max. room temperature 60 °C. Opening/closing time ca. 3 min. Length of cable 1 m. CE conformity: EN 60730.

---

### TE 3112

Electrothermic actuator, normally closed, with indicator of position and auxiliary contact. Clip mount on adapter with M30x1.5 thread. Supply voltage 230 V AC. Starting current 300 mA. Running current 8 mA. Working power 1.8 W. Limit switch control current 5 A resistive load and 1 A inductive load. Degree of protection IP 54. Protection class II. May be installed horizontally, vertically and upside down. Body in grey PA. Max. room temperature 60 °C. Opening/closing time ca. 3 min. Length of cable 1 m. CE conformity: EN 60730.

---

### TE 3113

Electrothermic actuator, normally closed, with indicator of position and auxiliary contact. Clip mount on adapter with M30x1.5 thread. Supply voltage 24 V AC. Starting current 250 mA. Running current 75 mA. Working power 1.8 W. Limit switch control current 3 A resistive load and 1 A inductive load. Degree of protection IP 54. Protection class III. May be installed horizontally, vertically and upside down. Body in grey PA. Max. room temperature 60 °C. Opening/closing time ca. 3 min. Length of cable 1 m. CE conformity: EN 60730.

---



Luxor S.p.A.

Sede amministrativa, stabilimento e uffici commerciali:

Administrative office, factory and commercial office:

Tel.: 030-9961161 – Fax: 030-9961165

info@luxor.it – www.luxor.it

via Madonnina, 94 – 25018 Montichiari - (BS) Italy

*Luxor si riserva il diritto di apportare miglioramenti e modifiche ai prodotti descritti ed ai relativi dati tecnici in qualsiasi momento e senza preavviso -  
Luxor reserves the right to ameliorate and modify the above products and their technical data at any time and without notice*