

FRIALEN® Safety Fittings for House Service and Supply pipings up to d 225

Assembly Instructions



FRIALEN® Safety Fittings:

1. Safety	3
2. Areas of application	3
3. Regulations and processing instructions	4
4. Couplers, Elbows, T-Pieces d 20 - d 225	6
5. Pressure Tapping Tees, Pressure Tapping Valves	14
6. Valve Tapping Saddles	20
7. Shut-off Saddles	21
8. Spigot Saddles	22
9. Reinforcement and repair saddles	22
10. FRIALOC® PE shut-off valve	23
11. Ball Valves	26
12. Tapping Ball Valves	27
13. Transition Fittings	27
14. Repair Sleeves for pipes d 32 – d 63, SDR 11	29
15. Updates of assembly instructions	30

For further information on the processing of FRIALEN® Safety Fittings, please contact:

FRIATEC Aktiengesellschaft
Technical Plastics Division
P.O.B. 710261 · D-68222 Mannheim
Phone +49 621 486-1431
Fax +49 621 479196
Internet: www.frialen.com
Email: info-frialen@friatec.de
Hotline +49 621 486-1486

1. Safety

1.1 Safety advice and tips

The following warning symbols are used in these assembly instructions:



DANGER!

Describes impending danger!

Non-observance of this warning may lead to serious damages to health and objects.



WARNING!

Describes a dangerous situation!

Non-observance of this warning may cause minor injuries or damage to objects.



IMPORTANT!

Describes advice and other useful information!

2. Areas of application

FRIALEN® Safety Fittings are used for weld joints at pressure pipes made of polyethylene in the dimensions SDR 17.6 to SDR 11 for use in gas and water supply, pressure drainage, industry and landfill construction.

FRIALEN® Safety Fittings can be fused with pipes of the dimensions SDR17.6 to SDR11, given a minimum wall thickness of at least ≥ 3.0 mm. Other fusion ranges, e.g. SDR7.4, are listed in the technical documentation and are directly identified on the product.

Please contact us for the processing of pipes with deviating wall thickness or SDR.

When operating with other media than drinking water and natural gas, please contact our application engineering department.



IMPORTANT!

The information and processing instructions mentioned on the fitting or enclosed shall apply predominantly.

3. Regulations and processing instructions

For detailed and up-to-date information on FRIALEN® Safety Fittings, please see the technical datasheets available on the Internet (www.frialen.com).

Please observe the guidelines of the DVGW regulations, of DVS, BGR 500 (VBG 50), EN 1555, EN 12201, EN 13244, accident prevention regulations and the relevant country-specific regulations.



DANGER!

The described sequence of the processes is absolutely to be adhered to.

FRIALEN® Safety Fittings can be used with pipes made of PE 100, PE 80, PE 63, PE 50 according to DIN 8074/75, EN 1555-2, EN 12201-2, EN 13244-2, ISO 4437 and ISO 4427, **PE-Xa** according to DIN 16892/93 (only up to pipe diameter 63mm; other pipe diameters on request), **LDPE** according to DIN 8072/73.

For PE pipes, a fusion flow rate MFR 190/5 in the range of 0.2 – 1.7g/10 min. applies.

We recommend using pipes with a limited dimension tolerance range, tolerance class B.

LDPE pipes can be fused at ambient temperatures > 0°C.

FRIALEN® Safety Fittings consist of PE 100 and meet the requirements according to DIN 16963-5, -7, EN 1555-3, EN 12201-3, EN 13244-3, ISO 4427-3, ISO 8085-3 as well as the DVGW test bases. FRIALEN® Safety Fittings can be fused with FRIAMAT® Electrofusion Units at ambient temperatures between - 10°C and + 45°C.

For material transition joints, the material- or system-specific standards and installation guidelines apply in addition.



WARNING!

Fusion with other pipe materials such as e.g. PP, PVC etc. is not possible.



WARNING!

During processing, pipes and fittings should have a balanced temperature level in the permissible range of application between -10°C and +45°C.



IMPORTANT!

FRIALEN® Safety Fittings are identified by a batch marking.

This reads from left to right:

- Production week (KW) (stamp 1+2)
- Production year (stamp 2)
- Material identification letter (stamp 3)

Example:



KW 14/01/E

Some component parts are directly identified in reading direction.

The FRIALEN® Fitting can be stored and processed for a long time, provided the general storage specifications are adhered to. When properly stored (in closed rooms or containers (boxes) and/or not exposed to UV radiation as well as effects of weather like humidity etc.), a storage and processing period of more than 4 years can be assumed.



WARNING!

Improperly stored component parts may not be processed because this may result in leaking fusion joints.



IMPORTANT!

Before installing the FRIALEN Fittings, please check if the parts are in perfect condition when delivered. Damaged parts may not be installed.

Traceability

An automatic component traceability is possible when using e.g. traceability-capable FRIAMAT® Electrofusion Units with a special barcode (see Fig. 9) which contains the specific data of the fitting, e.g. manufacturer, dimension, material, batch. These data on component traceability can be electronically archived together with the fusion process data.



IMPORTANT!

Manual electrofusion units (without barcode reader), e.g. FWS 225, are no longer state-of-the art. Processing of FRIALEN® Safety Fittings with these units is thus no longer possible.

3.1 Pressure load-bearing capability

The pressure load-bearing capability of FRIALEN® Safety Fittings made of PE 100 is determined by the identification SDR.

$$SDR = \frac{\text{Pipe outer diameter } \varnothing d}{\text{Pipe wall thickness } s}$$

The design factor C (calculation coefficient for PE components) depends on the area of application and the specifications (min. 1.25).

Fitting material: PE 100 (FRIALEN® standard)	Water	Gas
SDR Stage	maximum operating pressure in bar for C = 1.25	maximum operating pressure in bar for C = 2
17	10	5
11	16	10
7,4	25	-

The parts are identified and usable with regard to their load-bearing capability according to the above table.

For pressure classifications deviating from this identification, e.g. because of function-related limitations for FRIASTOPP®, the data on the fitting or in the technical data sheets are to be observed.



DANGER!

Fusion with escaping media is not permissible.

4. Couplers, Elbows, T-Pieces d 20 - d 225

4.1 Cutting to length of pipes

Cut off the pipe in a right angle to the pipe axis (see Fig. 1). A suitable tool is a PE pipe cutter or a saw with toothing suitable for plastics.



DANGER!

A non-rectangular pipe cutting may cause the heating coil partially not being covered by the pipe which may result in overheating, uncontrolled melt formation or self-ignition (see Fig. 2).

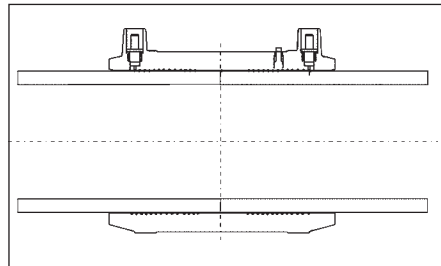

Fig. 1

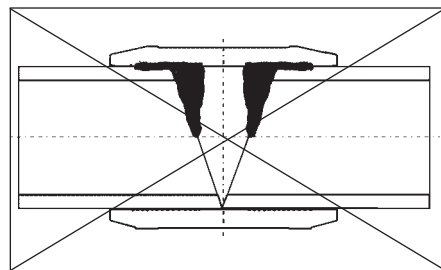

Fig. 2

4.2 Measure fusion zone, mark with a FRIALEN® marker and remove oxide layer

Fusion zone:

For **fittings** in general the insertion depth, i.e. the distance between the coupler edge and the internal stop.

For **slide over couplers**, the distance between the coupler edge and the centre of the coupler.

At first, remove contaminations from the pipe. A processing allowance of approx. +5mm in addition of the insertion depth provides proof after fusion that the oxide layer has been removed properly. Using a manual scraper or **FRIATOOLS® Scraper tools FWSG** (see Fig. 3-5), the oxide layer, which formed during on the surface of HDPE pipes and spigot fittings during storage, has to be removed completely directly before the assembly.

Pipe spigots, e.g. at fittings DAA, DAV..., ball valves KH, KHP or thread connecting adapters UAN/ UAM are to be prepared analogue to the processing specifications for pipes.

Rotational scraper tools are prescribed pursuant to DVS2207-1, Supplement 1, for the preparation of PE-X pipes.

An equal and seamless scraping is achieved by using FWSG scraper tools.

FWSG 63	d 20 - d 63
FWSG 225	d 75 - d 225
FWSG SE	d 63 - d 315*

*Dimension-dependent units for the processing of pipe ends and saddle fusion areas (Fig. 5)



Fig. 3

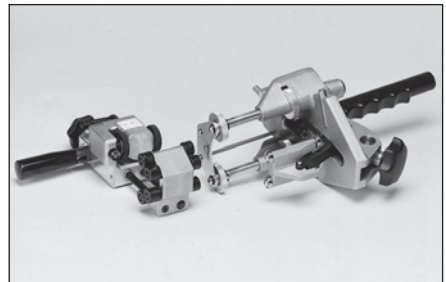

Fig. 4

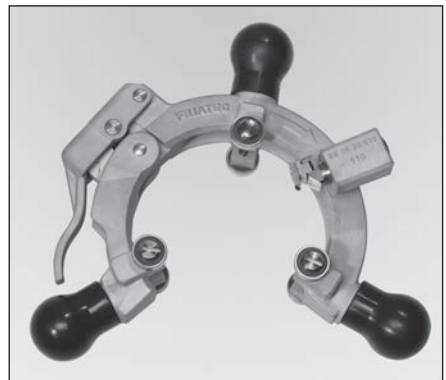

Fig. 5

The scraping result is to be verified.



WARNING!

If the oxide layer is not removed completely, inhomogeneous, leaking fusion joints may result.

A one-time, complete removal is sufficient (min. 0.15 mm). Damages to the pipe surface as e.g. axial grooves or scratches may not be located within the fusion zone.

WARNING!

An excessive swarf removal may result in an excessively large annular gap which either cannot or only insufficiently closed by fusion.

Please thus regularly check the condition of the blade at the manual scraper and the wear of the scraper blade at the scraper tool. Worn blades must be replaced (see FRIALEN® Info No. 1).

Scraper tool	Desired swarf thickness (mm)	Wear limit (mm)
FWSG 63	0.15 - 0.25	> 0.3
FWSG 225	0.25 - 0.35	> 0.4
FWSG SE ≤ d63	0.15 - 0.25	< 0.15 / > 0.3
FWSG SE > d63 - d225	0.25 - 0.35	< 0.15 / > 0.4

Please note that the indicated wearing margin applies to FRIALEN® Safety Fittings. Where appropriate please observe manufacturers' indications.

Filing or sanding are not permitted because contaminations are introduced.

For a control of the complete surface removal over the entire surface, we recommend to apply marking (control) lines (see Fig. 3). If during scraping of the surface non-scraped areas occur at some points (e.g. in case of bundled coil goods or oval pipes), these areas are to be reworked. The processed zone is to be protected against dirt, soap, grease, subsequently flowing water and unfavourable effects of weather (e.g. moisture, frost formation). Do not touch the fusion zone again after scraping.



WARNING!

FRIALEN® Safety Fittings with integrated heating coils guarantee optimal heat transfer through their exposed heating coils and may thus not be scraped at the inside of the fitting.

4.3 External and internal chamfering of the cutting edge

For this purpose, the manual scraper is a suitable tool. **Remove swarves from within the pipe.**

4.4 Restoration of irregular / oval pipes

Pipes, in particular bundled coils and drums, may lose their roundness during storage. If the pipe out-of-roundness in the fusion zone area exceeds 1.5% of d (outer diameter) or is > 3.0 mm, these pipes must be rounded in the fusion zone area. Please use rounding clamps for this purpose which are installed at the end of the fusion zone (see Fig. 6).

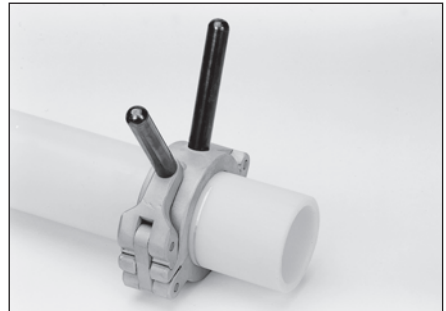

Fig. 6

4.5 Cleaning

The surfaces of the pipes to be fused and the interior surfaces of the **FRIALEN® Safety Fittings** must be absolutely clean, dry and free from any grease. These areas are to be cleaned with a suitable cleaning agent and **exclusively with absorbent, lint-free and non-dyed paper** directly before the assembly and after scraping (see Fig. 7).



Fig. 7

We recommend PE cleaning agents which meet the requirements of the test basis DVGW-VP 603, e.g. AHK cleaning agents.

The amount of the PE cleaning agent is to be chosen such that the paper is slightly wetted. Skin contact is to be avoided. Please observe the safety notes of the manufacturer of the PE cleaning agent.

When cleaning, ensure that no contaminations from the unscraped pipe surface are introduced into the fusion zone.



WARNING!

When using alcoholic cleaning agents, the alcohol percentage must be at least 99.8% according to DVGW-VP 603.

The cleaning agent **must be completely evaporated** before starting the fusion process.

Subsequently, re-apply marking line for the fusion zone width with the **FRIALEN® marker** because this line was removed during scraping and cleaning. The joint surfaces must be clean and dry before installing the fitting. The cleaned fusion zone should not be touched with bare hands. Moisture in the area of the joint area, e.g. because of dew or frost, is to be removed using suitable aids.

The fusion fitting is to be removed from the packaging only directly before the planned processing. The packaging protects the fittings against external influences during transport and storage.

4.6 Positioning of insertion or pipe ends into the fitting

When connecting **FRIALEN® Safety Fittings** and pipes, it is to be ensured that the contact sockets for connecting the fusion plug are accessible. **Do not jam when connecting.** The **FRIALEN® Safety Fittings** should be slipped on **without using force**. The processed insertion end must be inserted into the fitting up to the mark. If needed, rounding clamps (see Fig. 6) are to be used.

Repeated scraping may not be performed to remedy installation problems due to out-of-roundness!

If the fitting cannot be slipped on without using force despite the above described procedure, a repeated scraping is permitted.

A simple control of the high points is possible by installing the coupler and evaluating the annular gap.

4.7 Ensuring a tension-free assembly of the components

All joints prepared for fusion must be tension-free. Pipes may not be positioned in the **FRIALEN® Safety Fitting** under bending stress or self-load. After the installation on the pipe ends, it must still be possible to move the couplers by hand.

If required, the piping or the fitting is to be supported or suitable fixing facilities are to be used. The tension-free fixing of the joint is to be maintained until the cooling time stated on the barcode and in the table (see Item 4.9) is reached.

Before starting the fusion process, check again based on the markings whether the position of the pipe insertion end in the FRIALEN® Safety Fitting has shifted (correct, if required).



WARNING!

A non-tension-free or shifted joint may result in an impermissible melt flow and a defective joint during fusion (see Fig. 8).

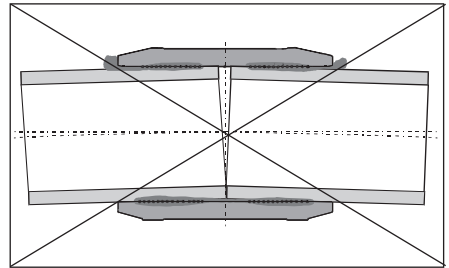

Fig. 8

4.8 Carrying out fusion



WARNING!

Only use fusion units which have been approved by the manufacturer with regard to their function for the processing of FRIALEN® Safety Fittings. See DVS 2207-1.

The fusion parameters are contained in the main barcode affixed to the **FRIALEN® Safety Fitting**. When using fully automatic fusion units (e.g. **FRIAMAT®**), the parameters are entered into the fusion unit using the reader.



Fig. 9

The subordinated barcode contains the data for component traceability (see information 2). This barcode is only to be read if the component traceability function is to be used. This requires suitable fusion units.

FRIALEN Fittings: 39.5V processing

FRIALEN Fittings are processable for electrofusion units with a constant output voltage of 39.5V by manual input of the fusion time.

On demand we can provide a list with suitable fittings. For the manual input of the fusion parameters, the fusion time is stated on the fitting barcode (see Fig. 10).



Fig. 10



IMPORTANT!

By using electrofusion units with constant output voltage, the allowed processing range by an ambient temperature is between $-5\text{ }^{\circ}\text{C}$ and $+35\text{ }^{\circ}\text{C}$. The stated fusion time on the fitting barcode is for the complete temperature range.

The fusable pipe series are listed in the SDR labelling on the label.

The fusion units automatically monitor the fusion process and control the supplied energy in determined limits.



INFORMATION:

The fusion parameters are encoded on the barcode label in the form of a 24-digit figure (top), the data for component traceability in the form of a 26-digit column of numbers (bottom), and can also be entered manually into the FRIAMAT® fusion unit using the emergency entry mode.

For fittings with separate coils (see Fig. 11), each fitting side is to be fused separately.

For fittings with continuous coil, both fitting sides are to be fused simultaneously (see Fig. 12).

For **FRIALEN® Safety Fittings** equipped with a fusion indicator, the latter only indicates to the performed fusion process. The proper fusion process is, however, only indicated by the fusion unit!

After reading of the barcode, the fitting data are to be compared with the data shown on the unit's display. If they are identical, **start fusion**. Please observe the operating instruction of the FRIAMAT® fusion unit.

Avoid stress on the connecting spot.

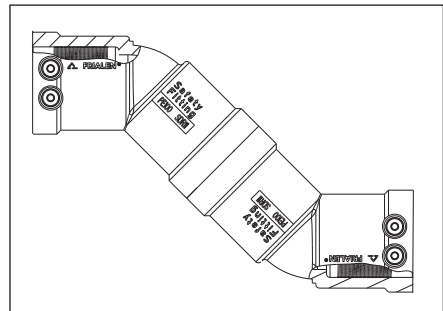

Fig. 11

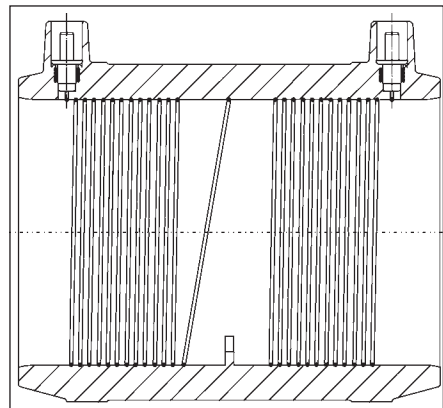

Fig. 12



WARNING!

Keep a distance of one meter to the fusion site during the fusion process for general safety reasons.

The obtained **actual fusion time** is to be compared with the **target fusion time** on the unit and to be noted on the pipe or the **FRIALEN® Safety Fitting** (see Fig. 13).

With this identification it is ensured that no fusion point is overlooked.

In case of doubt, a fusion can be repeated. But the joint surfaces must be cooled down to ambient temperature before each renewed fusion. Please contact for this purpose your local FRIALEN® sales engineer by phone or the FRIALEN® Hotline.



Fig. 13

4.9 Cooling times.

The cooling time is

- a) the time which is required to cool down the component to the temperature which facilitates the movement of the joint. This time is also listed on the barcode and is identified by CT.
- b) the time which is required to cool down the component to the temperature which facilitates the application of the full test or operating pressure. This is classified into pressure volumes of up to 8 bar and > 8 bar.

Diameter in mm	Cooling time in minutes for FRIALEN® couplers and fittings		
	CT until the joint may be moved	Up to pressurising at up to 8 bar	Up to pressurising at > 8 bar
20 – 32	5	8	10
40 – 63	7	15	25
75 – 110	10	30	40
125 – 140	15	35	45
160 – 225	20	60	75



INFORMATION:

A piping may only be commissioned after successful pressure test (see EN 805, EN 12007 and DVGW G 469, W 400).

The guidelines of the DVGW leaflets for pressure tests, the European standards or the country-specific regulations are to be observed.

5. Pressure Tapping Tees, Pressure Tapping Valves

FRIALEN® Pressure Tapping Tees and **Pressure Tapping Valves** are suitable to be used as branches for unpressurised and pressurised pipings.



WARNING!

Saddle components d 40 – d 63 cannot be processed with SDR 17 HD-PE pipes.

For tapping-technical reasons, **FRIALEN® Pressure Tapping Tees** can in general not be processed with SDR 7.4 pipes, and **pressure tapping valves** can in general not be processed with SDR 7.4 and SDR 9 pipes.

Please read our fitting data sheets or ask the **FRIALEN®** application engineer.

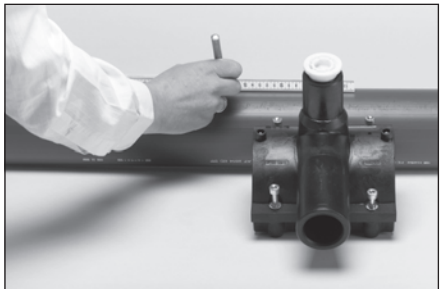

Fig. 14

5.1 Measuring of fusion zone of the pipes (and the lateral outlet spigot), marking and removing oxide layer

At first, remove contaminations from the pipe.

Fusion zone: is the pipe surface covered by the upper part (see Fig. 14); in case of lateral outlets the insertion depth at the smooth fusion

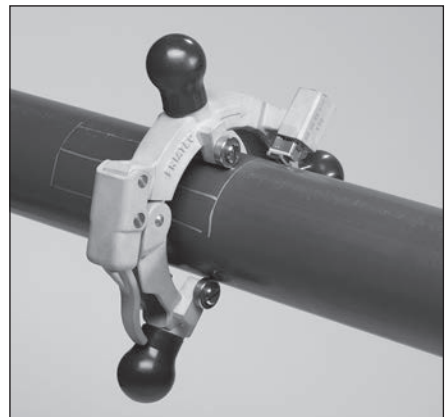

Fig. 15

end. Using a FRIATOOLS® Scraper tool (see Fig. 15), the oxide layer, which formed during on the surface during storage, has to be removed **completely** from the area of the fusion zone directly **before** the assembly.

A processing allowance of several millimetres in addition to the covered area provides proof after fusion that the oxide layer has been properly removed from the pipe.



WARNING!

If the oxide layer is not removed completely, leaking fusion joints may result.

Worn blades of the scraper tool and manual scraper must be replaced.

A one-time, complete removal is sufficient (min. 0.15mm). A uniform surface without flattening and material grates at the pipe diameter should be the result.



WARNING!

Filing or sanding of the pipe is not permitted because contaminations are introduced.

For a control of the complete surface removal over the entire surface, we recommend to apply marking (control) lines. If during scraping of the surface non-scraped areas occur at some points, these areas are to be reworked.

The processed zone is to be protected against dirt, soap, grease, subsequently flowing water and unfavourable effects of weather (e.g. moisture, frost formation).

5.2 Cleaning

The surfaces of the pipes to be fused and the interior surfaces of the **FRIALEN® Safety Fittings** must be absolutely clean, dry and free from any grease. These areas are to be cleaned with a suitable cleaning agent and **exclusively with absorbent, lint-free and non-dyed** paper directly before the assembly and after scraping. We recommend PE cleaning agents which meet the requirements of the test basis DVGW-VP 603, e.g. AHK cleaning agents.

When cleaning, ensure that no contaminations from the unscraped pipe surface are introduced into the fusion zone.



WARNING!

When using alcoholic cleaning agents, the alcohol percentage must be at least 99.8% according to DVGW-VP 603.

The cleaning agent **must be completely evaporated** before starting the fusion process.

Subsequently, re-apply marking line for the fusion zone width with the **FRIALEN® marker** because this line was removed during scraping and cleaning. The joint surfaces must be clean and dry before installing the fitting. The cleaned fusion zone should not be touched with bare hands. Moisture in the area of the joint area, e.g. because of dew or frost, is to be removed using suitable aids.

The fusion fitting is to be removed from the packaging only directly before the planned processing. The packaging protects the fittings against external influences during transport and storage.

5.3 Assembly

- Loosen pre-mounted screws on one side.
- Open upper and lower part; still screwed side serves as hinge.
- Place onto processed pipe area.
- Tighten all four screws equally cross-wise **up to the stop** using an Allen wrench (see Fig. 16).

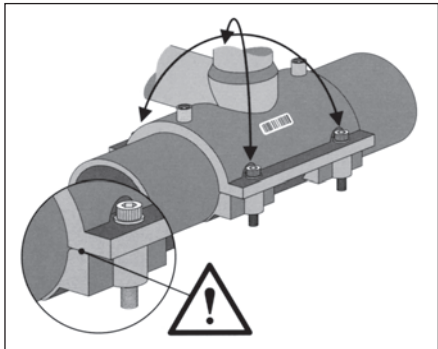

Fig. 16

Allen wrench	Fitting
SW 5	up to d 75
SW 6	from d 90

Bottom parts are a component part of the fittings and serve the application of the joining pressure.



WARNING!

For pressure tapping tees and pressure tapping valves, the factory drill setting may not be changed before starting the fusion process.

5.4 Carrying out of fusion

When fusing **Pressure Tapping Tees and Valves** to media-carrying pipings, the following operating pressures may not be exceeded until the pipe has cooled down completely:

Pipe material	PE 80		PE 100	
SDR	17	11	17	11
Maximum permissible operating pressure in bar				
Gas pipe	2	5	5	10
Water pipe	8	12,5	10	16



WARNING!

Only use fusion units which have been approved by the manufacturer with regard to their function for the processing of FRIALEN® Safety Fittings. See DVS 2207-1.

The fusion parameters are contained in the main barcode affixed to the **FRIALEN® Safety Fitting**. When using fully automatic fusion units (e.g. **FRIAMAT®**), the parameters are entered into the fusion unit using the reader. After reading of the barcode, the fitting data are to be compared with the data shown on the unit's display. If they are identical, **start fusion**. Please observe the operating instruction of the FRIAMAT® fusion unit.

A pressure test of the branch line can be performed before tapping the main line.

The fusion units automatically monitor the fusion process and control the supplied voltage in determined limits.

The indicator only indicates to the performed fusion process. The proper fusion process is, however, only indicated by the fusion unit!



WARNING!

Keep a distance of one meter to the fusion site during the fusion process for general safety reasons.

The obtained ACTUAL fusion time is to be compared with the target fusion time on the unit and to be noted on the pipe or the FRIALEN® Safety Fittings.

With this identification it is ensured that no fusion point is overlooked.

5.5 Tapping and application of the test and operating pressure

The following waiting times are to be observed:

Diameter in mm	Cooling time in minutes for FRIALEN® Saddle fittings	
	Up to pressurisation via outlet	CT Up to tapping
40 – 63	15	20
75 – 125	20	30
140 – 160	30	45
180 – 225	50	60

The cooling time CT stated on the components corresponds to the cooling time until tapping.



WARNING!

If the waiting times are not observed, leaking fusion joints may result. The general installation instructions must be observed before tapping.

5.6 Tapping of Pressure Tapping Tees

Remove blanking plug. Turn the drill down up to the lower stop using the matching FRIALEN® activating key (see Fig. 17).

d	SW
40	10
50 to 75	17
DAA d ₁ 63 / d ₂ 63	19
≥ 90	19



Fig. 17

Turn the drill backwards up to the upper stop.

Position the blanking plug and turn down the FRIALEN® activating key until the collar of the plug **slightly touches** the front face of the drill spigot.

Subsequently, turn back the plug **half a turn** to relieve the O-ring tension.



WARNING!

If the collar is excessively tightened, the plug may break or the hexagonal seat may be overwound. In this case, the plug has to be replaced.

We recommend closing the tapping dome with a fusion cap K. The required scraping and cleaning are to be performed (see Chapter 4.1 - 4.9).

5.7 Tapping of Pressure Tapping Tees with parallel outlet

Tapping (see Fig. 18) is made analogue to Item 5.6 with the activating key for pressure tapping tees with parallel outlet.

5.8 Tapping of Pressure Tapping Valves

Installation, fusion and cooling times as 5.1 et seq.

Tap with a suitable key via the 14mm square turning clockwise (see Fig. 19) until the lower stop is reached. The valve is now closed. In order to open the valve, the drill has to be turned anti-clockwise until the stop. The metallic stops for the positions “open” and “closed” of the valve result in a clearly noticeably increase in the activation force.

Because sealing in the closed state is made through a radially pressed O-ring, an excessive closing is not required.

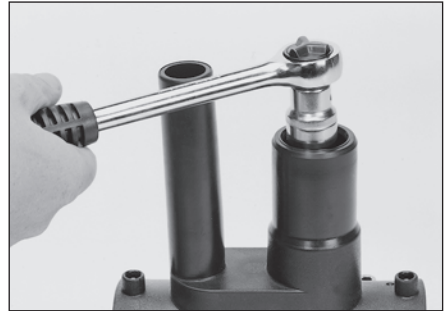

Fig. 18



Fig. 19



INFORMATION:

A subsequent tapping from the surface box using the FRIALEN® EBS is possible.

Connect the 14mm square of the pressure tapping valve to the **FRIALEN® installation kit EBS** and protect with a cotter pin against coming loose. Adjust the required covering height at the extendable activation rods. The telescopic rods can be adjusted continuously and is fixed safely at its extension position. The **FRIALEN® EBS** is technically optimally matched to the **FRIALEN® pressure tapping valve**.

6. Valve Tapping Saddles

6.1 Assembly

The preparation of the installation and the fusion process is made analogue to the **FRIALEN® Pressure Tapping Tee** (see 5.1 - 5.4).

The cooling times are to be observed (see item 5.5 **Pressure Tapping Tee**).



Fig. 20

The tee is tapped with a corresponding lock assembly or installed with a valve according to the installation instructions of the different valve manufacturers. The preparation and performance of the pressure test is made according to the valve manufacturer's instructions.



DANGER!

The factory-installed metallic torque parts must be protected against turning out of position using a key.



IMPORTANT!

The insulation work has to be carried out properly (DVGW regulations).

7. Shut-off Saddles

7.1 Assembly

FRIALEN® Shut-off Saddles (see Fig. 21) are prepared for installation and welded analogue to **FRIALEN® Pressure Tapping Tees** (see Chapters 5.1 – 5.4). The tapping of the pipe can be made after cooling down (see Item 5.5) and observing the installation instructions of the tapping/shut-off saddle installation equipment of the relevant manufacturer.

Installing the brass plug

The plug is to be screwed in such that the O-ring seals in the dome. In the end position, the plug protrudes from the dome sleeve by approx. 1.5 mm (fig. 22). Screwing in requires a torque of approx. 150 Nm. This can be obtained using a suitable tool aided, if required, by a lever.

Having installed the brass plug, either the plastics cap has to be screwed in or a **FRIALEN® Cap for Shut-off Saddles SPAK** (for SPA d 63, K d 50 has to be fused, taking into consideration the usual scraping and cleaning (Fig. 23).



Fig. 21



Fig. 22



Fig. 23

8. Spigot Saddles

8.1 Assembly

The preparation of the installation and the fusion process is made analogue to the **FRIALEN® Pressure Tapping Tee** (see 5.1 - 5.4).



Fig. 24



WARNING!

The tapping is made with commercially available tapping units in an un-pressurised state with or under pressure using shut-off valves.

We recommend the tapping unit of the company of Hütz + Baumgarten, Remscheid (www.huetz-baumgarten.de), especially designed for this purpose.

Please ask our FRIALEN® Application Engineering Department.

The manufacturer's installation instructions are to be observed.

9. Reinforcement and repair saddles

9.1 Assembly

In case of selective pipe damages, the damaged area can be closed with a plug and then fused with the reinforcement and repair saddle.

Each half shell is to be fused separately.

The preparation of the installation and the fusion process of the individual half shells is made analogue to the **FRIALEN® Pressure Tapping Tee** (see 5.1 - 5.5).



Fig. 25



WARNING!

It is to be ensured that the damaged or deformed part of the piping is always located in the centre of the heating element during installation and at least at a distance of 10 mm from the inner heating coil to the interior.

10. FRIALOC® PE shut-off valve

10.1 Areas of application

FRIALOC® PE shut-off valves made of PE 100 can be used in water supply systems according to DVGW (German Technical and Scientific Association for Gas and Water) W400-2 and EN 805 with a maximum component part operating pressure PFA (PN) of 16 bar.

FRIALOC® PE shut-off valves meet the requirements on component parts for use in water supply systems according to DIN EN 12201-4 and DVGW VP647.

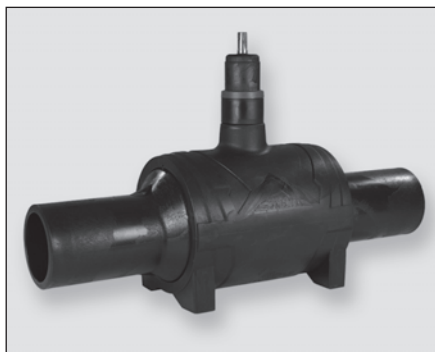

Fig. 26

For the planned installation of FRIALOC® PE shut-off valves into other piping systems, please state the flow medium and the operating conditions (pressure, temperature, planned period of use...) to clarify if our application technology is suitable.

The preferred type of installation of FRIALOC® PE shut-off valves is a material-homogeneous installation in PE piping systems using FRIALEN® safety fittings. Using the fusion flanges FRIALEN® EFL, installation into pipings made of other materials is also possible. When using mechanical joining methods, e.g. FRIAGRIP, the specific installation instructions are to be observed. Internal supporting sleeves may only be inserted up to the end of the pipe spigot of the FRIALOC® at the most, because otherwise the shut-off valves would be blocked.

FRIALOC® PE shut-off valves can be both buried or installed in systems above ground.



INFORMATION:

For up-to-date and detailed information on FRIALOC® PE shut-off valves, please see the technical datasheets available on the Internet (www.frialen.com).

10.2 Identification

FRIALOC® PE shut-off valves possess a coloured identification ring which contains information about dimension, pressure range etc. as well as the individual component part number. With the help of these component part numbers, the data of the installation process archived by the company, including the batch data of the component parts used and the accompanying tests can be traced. Within the scope of the accompanying tests, each individual FRIALOC® PE shut-off valve is tested for leak-tightness, strength, function, and actuation torque in a multilevel process. The individual component part number may also be automatically archived in the FRIAMAT® fusion protocol by reading the traceability bar code on the fitting.



Fig. 27

FRIALOC® PE shut-off valves are supplied in a packaging made of cardboard and are to be stored in a dry place, protected against contamination, high temperatures, and damage. Gaskets must be protected against permanent exposure to sunlight.

10.3 Storage

FRIALOC® PE shut-off valves are supplied in a packaging made of cardboard and are to be stored in a dry place, protected against contamination, high temperatures, and damage. Gaskets must be protected against permanent exposure to sunlight.

10.4 Processing instructions

Please check that the component part is in perfect condition when delivered before installing it. Damaged valves may not be installed. The pipe connecting couplers of the FRIALOC® PE shut-off valves have a double fusion length and correspond in the joining area to the geometric requirements on PE pipes according to DIN EN 12201-2.

In order to prevent contaminations, the protective covers should only be removed from the pipe connecting couplers directly before installation. The connection is made by FRIALEN® fusion according to the processing specifications of these installation instructions or specific procession instructions.

The FRIALOC® PE shut-off valve is equipped with an identification disk (Fig. 28) which can be installed at the actuation rods in the surface box and

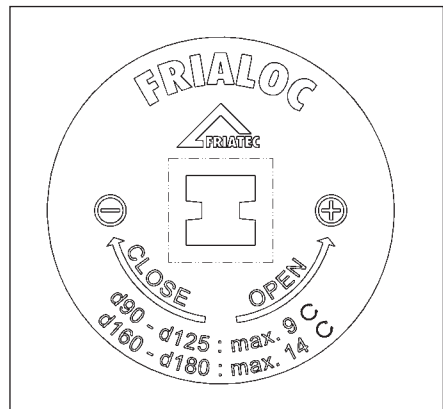

Fig. 28

which contains information about the sense of rotation as well as the torques for opening and closing of the valve.

The shut-off valve is delivered in closed condition.

A bottom plate can be used to increase the support area of the FRIALOC® PE shut-off valve in the ditch bottom. The bottom plate made of PE is installed at the four supports of the FRIALOC® PE shut-off valve by using suitable screws.

The valve may not be designed as fixed point of the piping to absorb forces such as e.g. flow impulses because of change of direction of the flowing material or because of thermal elongation of the pipes.

The valve must be sufficiently covered before working with the usual ground compacting devices.

10.5 Test

Pressure test

The piping is subjected to a pressure test according to W400-2, which may only be performed with fully opened valve.

Flushing

The piping is flushed according to W400-2 with opened valve.

10.6 Operation

The FRIALOC® PE shut-off valve is closed clockwise (closing to the right) and opened anti-clockwise.

The sense of rotation and the number of torques for actuation may be read from the identification disk in the surface box (see 10.4).

The FRIALOC® PE shut-off valves are not designed for continuous controlling of the flow.

The final “open” and “closed” position of the FRIALOC® PE shut-off valve is clearly signalled to the user by metallic stops.

The desired coverage height can be freely adjusted telescopically with the FRIALEN® actuation rods FBS and overstressing of the valve drive is thus prevented. FRIALOC® and FBS are ideally matched. The pipe sleeve bell is pushed onto the dome of the FRIALOC®. Hooks of the pipe sleeve then engage in recessions in the dome and create a stable and dirtproof connection. This connection can be released again by turning the pipe sleeve anti-clockwise.

When installing in systems, the FRIALOC® PE shut-off valve is operated via the hand wheel FHR. The hand wheel is directly installed on the spindle square.

10.7 Maintenance

FRIALOC® PE shut-off valves are maintenance-free. The inspection intervals according to DVGW-leaflet W392 are to be observed.

10.8 Tapping under pressure

Please contact our Application Engineering Department!

11. Ball Valves

The **FRIALEN® Ball Valve KH/KHP** (see Fig. 29) closes and opens by a 1/4 turn of the activating element.

The **FRIALEN® Ball Valve KH/KHP** is connected to the piping with its HDPE fusion ends using **FRIALEN® Couplers, Elbows or T-pieces**. It is suitable both for selective network isolation as well as for isolating house service pipings.



Fig. 29

11.1 Assembly

The fusion ends are prepared according to the general installation requirements (remove oxide layer/clean). Before starting the fusion process, the **FRIALEN® Ball Valve head KH/KHP** must be aligned corresponding to the planned actuation to guarantee a correct positioning of the activation rod BS.

The extendable **FRIALEN® Installation Kit BS** has been especially designed for the technical and geometric demands of the KHP Ball Valve.



WARNING!

Media identification and closing direction can be marked on the surface box using a marking disk.

12. Tapping Ball Valves

12.1 Assembly

The preparation of the installation and the fusion process of the tapping ball valve AKHP (Fig. 30) is made as saddle component analogue to the **FRIALEN® Pressure Tapping Tee** (see Items 5.1 - 5.5).



Fig. 30



INFORMATION:

For a leakage-free tapping of pressurised pipings, we recommend the tapping unit of the company of Hütz + Baumgarten, Remscheid (www.huetz-baumgarten.de). Please ask our Application Engineering Department.

13. Transition Fittings

13.1 Assembly



WARNING!

When removing the PE protection lid, please ensure that the wire is not damaged.

The general installation instructions for the **FRIALEN® Safety Fittings** (see Chapters 4.1 - 4.9) are to be observed.

13.2 Transition Fittings with steel pipe



WARNING!

In addition, the following items are to be considered:

- A shortening of the steel pipe is impermissible because the heat introduction during fusion has a negative effect on the sealing system.



Fig. 31

- Fusion of the steel side only by arc welding.
- When fusing the steel end it has to be prevented that fusion vapour and fusion beads get into or to the **FRIALEN® Coupler** with integrated heating coil.

Prevention:

Insert HDPE pipe section, which can be removed afterwards, into the **FRIALEN® Coupler** without using force and close at pipe end to prevent any suction effects.

The insulation is to be made according to the valid regulations as well as the manufacturer's instructions. The barcode may not be covered by the insulation.



Fig. 32

FRIALEN® Transition Fittings with steel pipe (only for gas applications, see Fig. 32).

13.3 Transition Fittings with threaded connection

- Gas steel thread (Fig. 33)
- Water Brass/gunmetal thread (Fig. 34)



Fig. 33

During the further course of installation, the factory-installed metallic threaded parts must be protected with a key against turning out of position in the plastics component.



WARNING!

The threaded connection may absolutely not be metallically fused or soldered. For insulation to be made, if any, Chapter 13.2 applies.



Fig. 34

14. Repair Sleeves for pipes d 32 – d 63, SDR 11

Water

The sleeve (Fig. 35) prevents the subsequent flow of residual water into the fusion zone during repair or connection to house service pipings for water (Fig. 36).

14.1 Assembly

For a repair of the damaged water pipe, a fitting piece with two slide over couplers **FRIALEN® UB** and two repair sleeves **FRIALEN® RW** is prepared.

The water pipe has to be bend correspondingly to install the fitting piece. Having positioned the slide over couplers, fusion is made analogue to Items 4.2-4.9.



Fig. 35

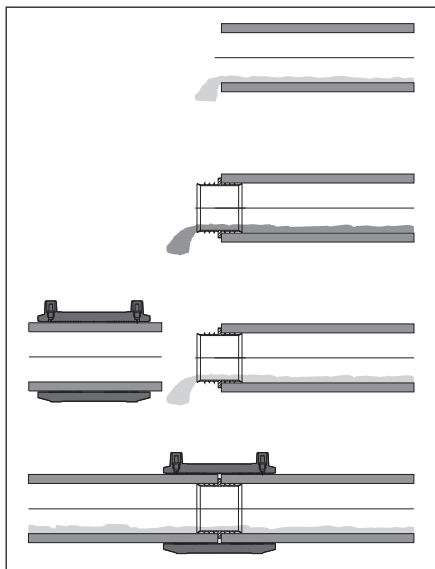

Fig. 36

15. Updates of assembly instructions

Further operating and assembly instructions are available:

- FRIALEN® Large Pipe Technique for laying large pipes and relining pipe networks
- FRIAFIT® Sewage System
- FRIAMAT® Electrofusion Units
- FRIATOOLS® Scraper Tools
- FRIATOP Clamping Unit
- FWFIT Clamping and Drilling Unit

These technical statements are regularly revised to be up-to-date. The date of the last revision is stated on the document.

For an updated version of the operating instructions, please visit our website www.frialen.com on the Internet. We will also mail them to you on request.

FRIATEC Aktiengesellschaft · Technical Plastics Division
P.O.Box 71 02 61 · D-68222 Mannheim
Phone: +49 621 486-1431 · Fax: +49 621 479196
E-Mail: info-frialen@friatec.de · www.frialen.com

