

Two-pipe distributor 715-915-916

Description

Two-pipe isolation with or without insulation

Versions

Isolation	With or without
Pipe connection	Male M22, 3/4E
Radiator connection	With or without 2 o'ring
Outflow	Vertical or latéral

Benefits

- The distributors provides an all-in-one solution for 1-pipe, with isolation and by-pass
- Included in the distributor, the mechanical connection of the distributor to the tube.



Conception

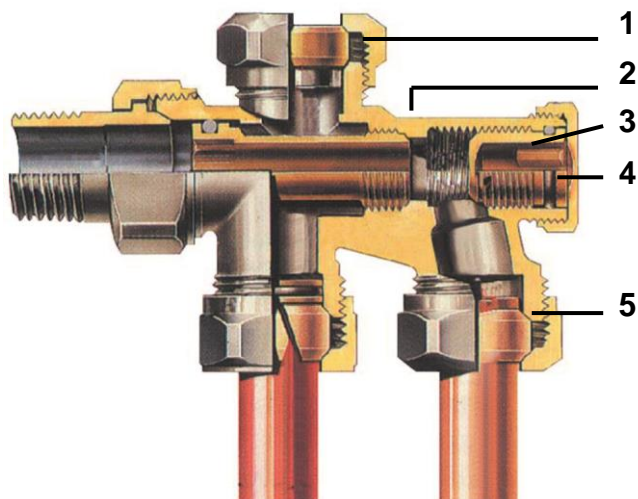

1. Pipe fitting
2. Two-pipe distributor
3. Memory
4. Isolation and balancing spindle with memory.
5. Main pipe fitting

Principle

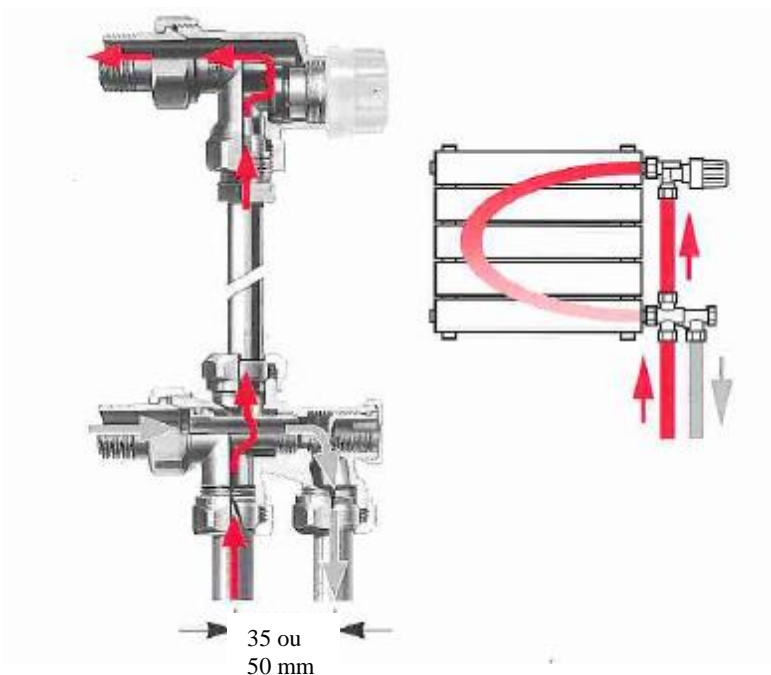

Each radiator is connected to two pipes. This distribution is the most used.

The advantages of this system are:

- Possibility to add or remove a radiator
- The sizing calculations are very easy
- Balancing single loop is not useful
- It is necessary to make a balance to obtain a proper flow

Specification





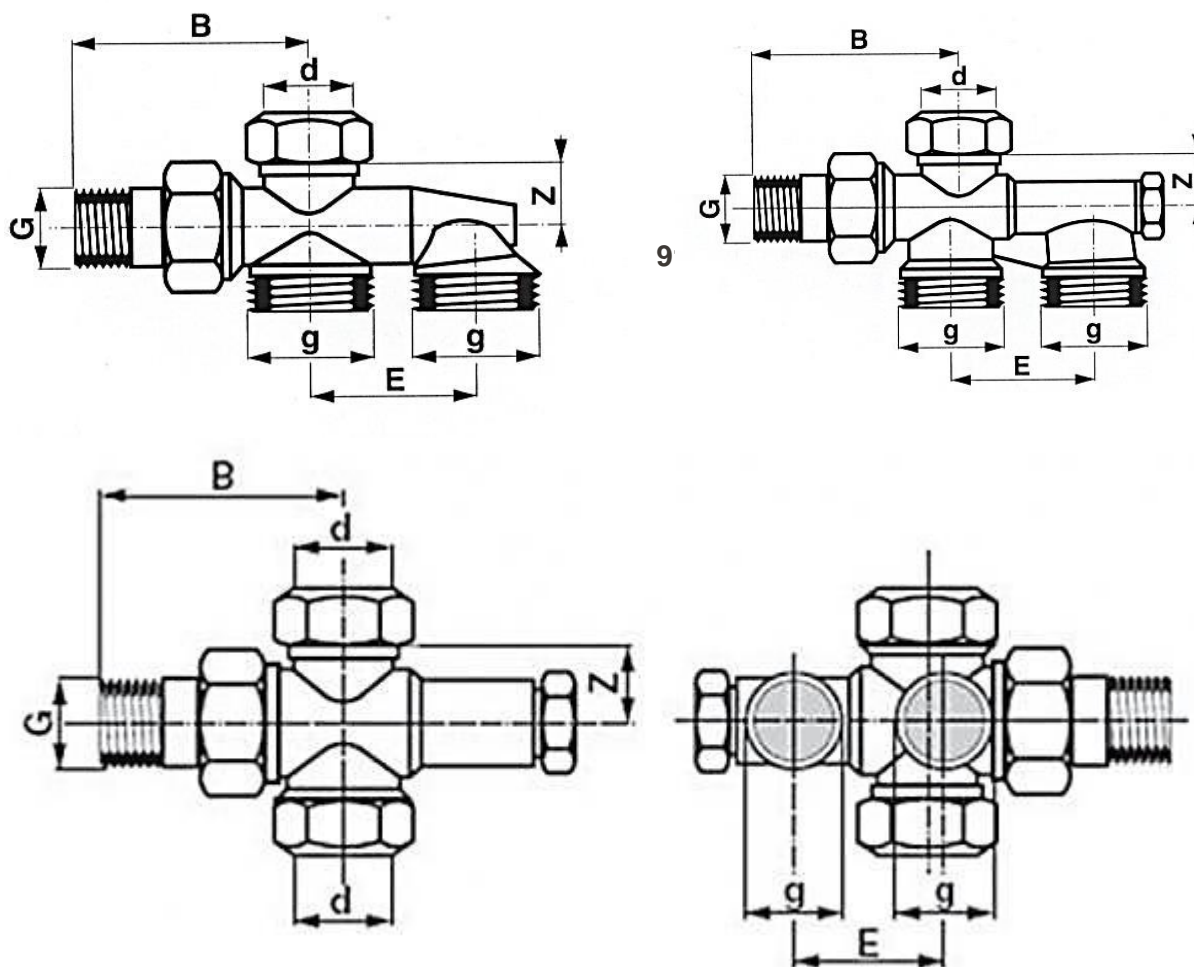

Heating water system
Maximum pressure of use: 10 bar
Maximum water temperature: 110°C

Dimensions



Model	Part	G	g	B	d	E	Z
715	438722	1/2"	M22x1.5	51	15	35	10
715JT	438722B	1/2" 2O-rings					
915A	438954	1/2"	1/2"				
915E	438922	1/2"	M22x1.5				
915EJT	438922B	1/2" 2O-rings	M22x1.5	51			
D915	915406	1/2"	3/4"E	51	15	50	10
916	916422	1/2"	M22x1.5	53	15	35	11.5
916JT	916422B	1/2" 2O-rings	M22x1.5		15	35	11.5

Product line

Photo	Alimentation	Radiator connection	Pipe connection	Isolation	Codes
	Vertical	1/2"	M22	Not	438722
		1/2" 2O-rings	M22		438722B
		1/2"	1/2"	Yes	438954
		1/2"	M22		438922
		1/2"	3/4"E		915406
		1/2" 2O-rings	M22		438922B
	Lateral	1/2"	M22		916422
		1/2" 2O-rings	M22		916422B

Hydraulic curves
715E-915E-915A-D915 1/2"

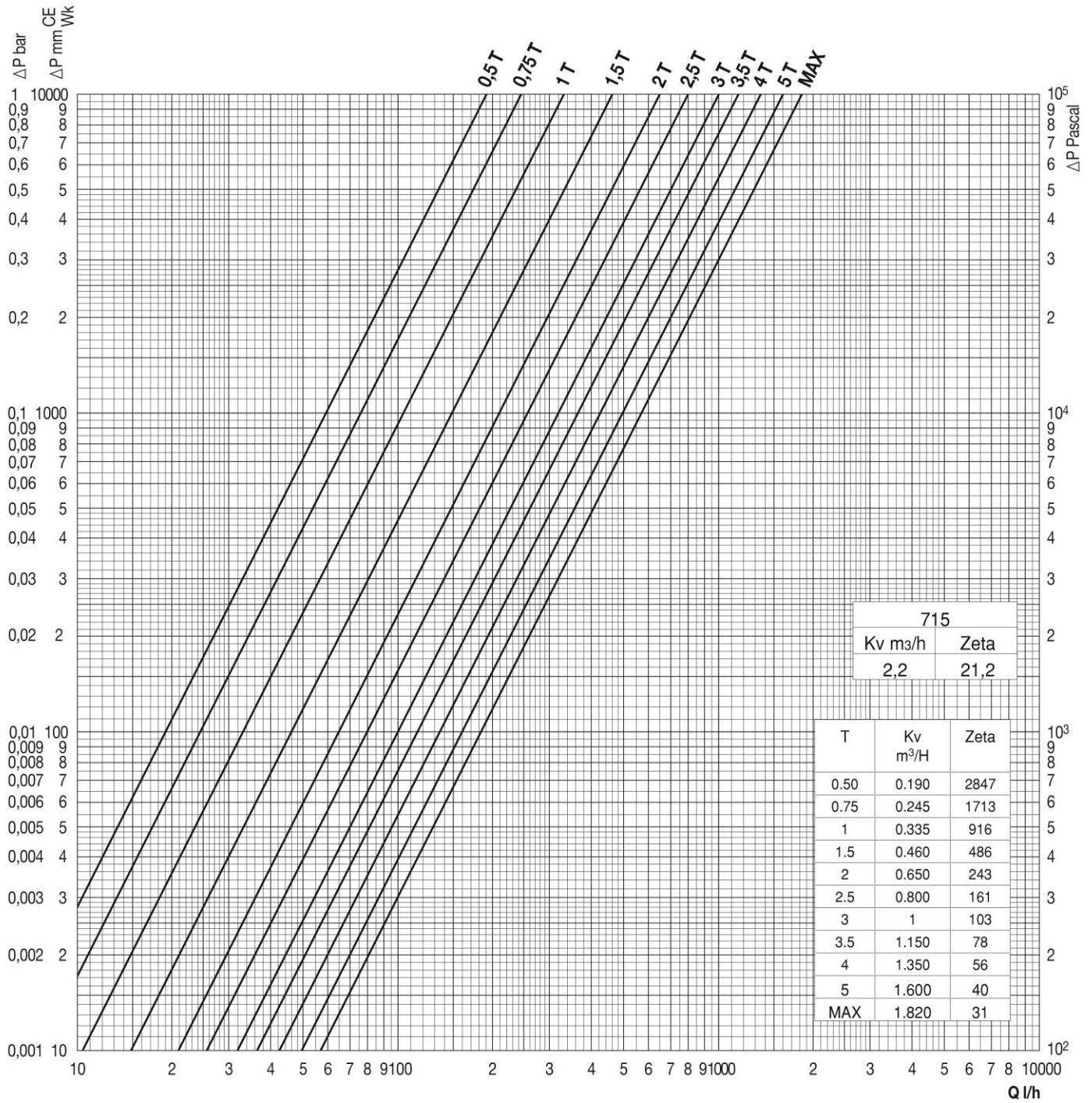

916E 1/2"

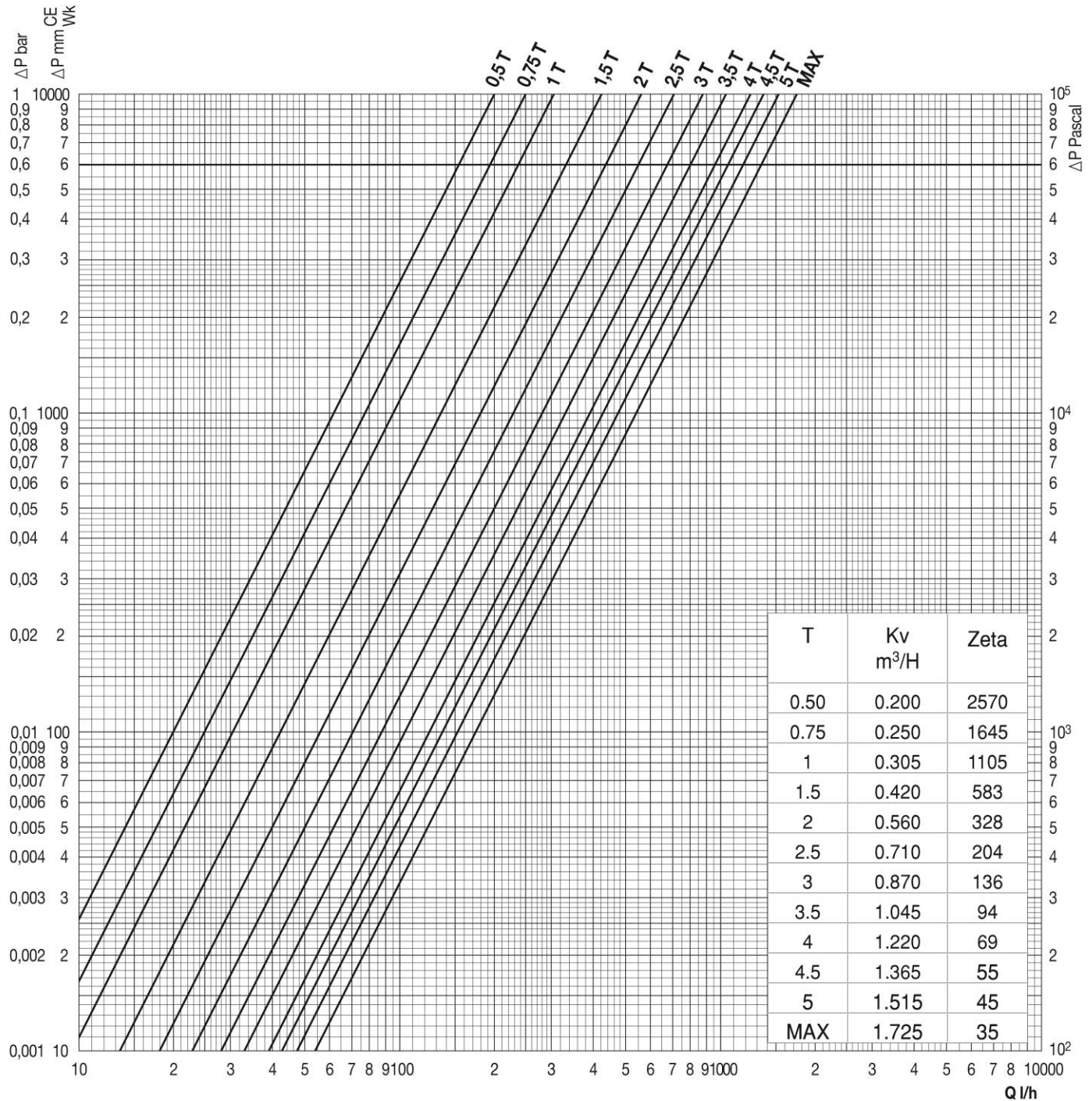

Combinations

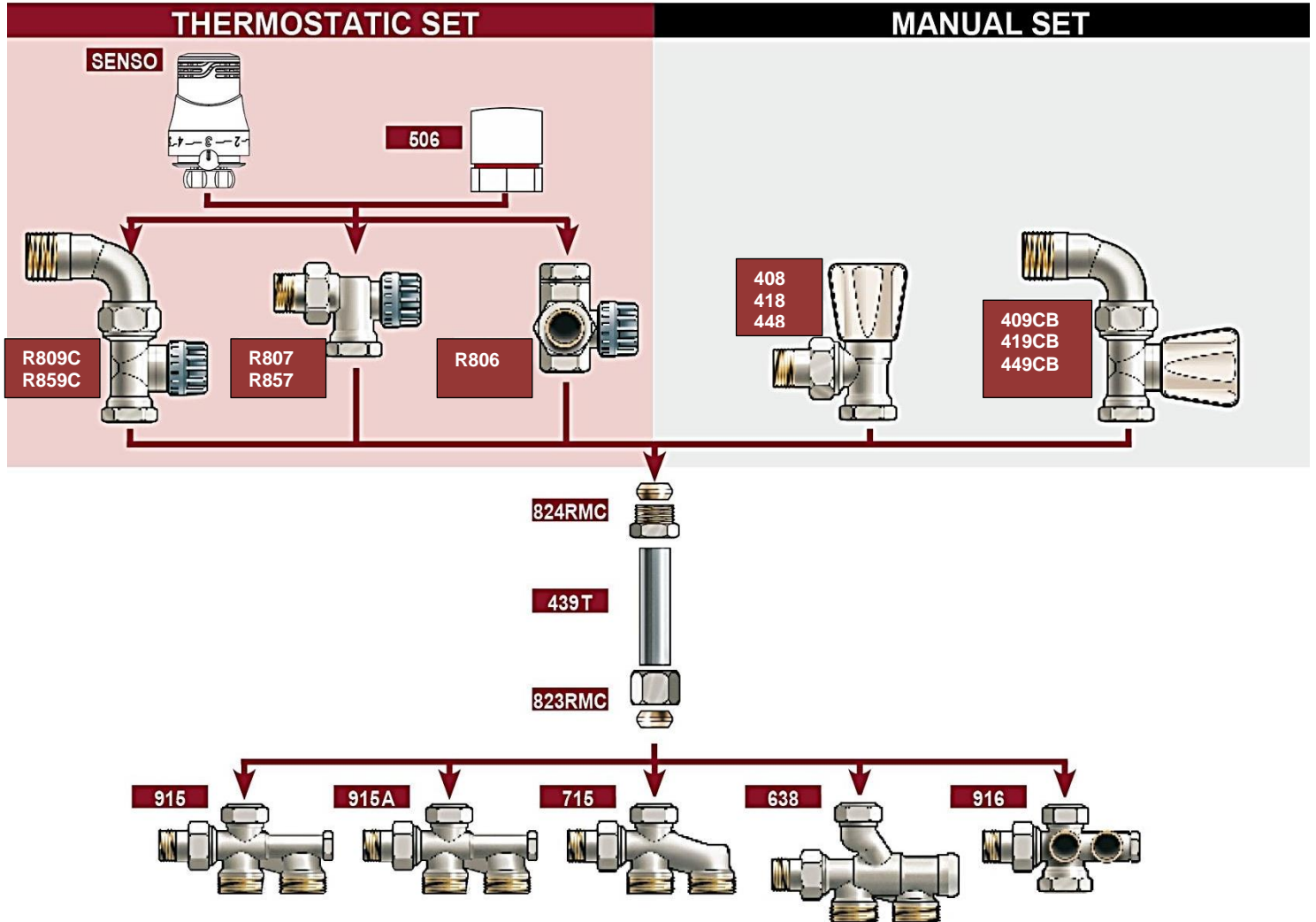

Connection

DISTRIBUTORS

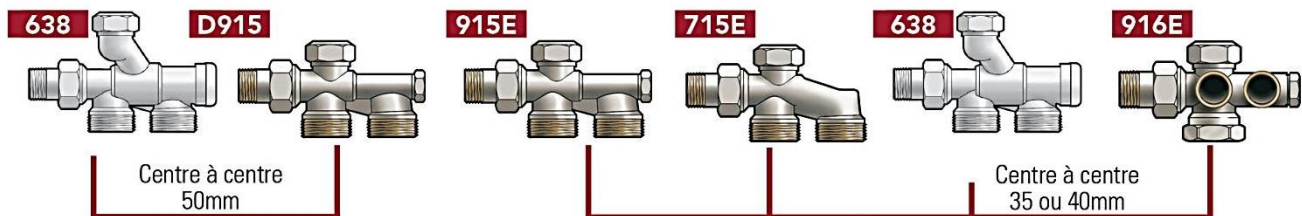

EUROCONUS

M22

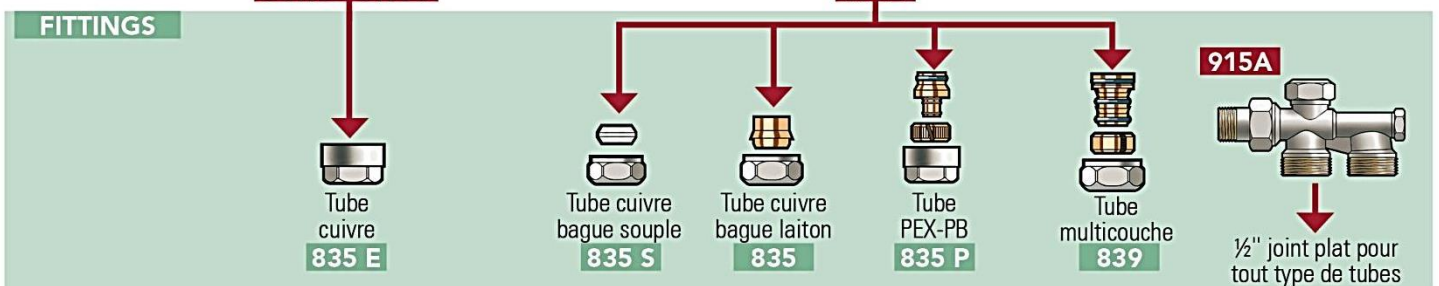

Accessories

Photo	Designation	Dimensions	Codes
	Tube 439T	d 15mm L 1.1m	559110
	Compression fitting 824RMC	15mm 1/2"	824402
	Compression fitting 823RMC	15mm M22	823415
	Olive compression fitting 835	10	835410
		14	835414
		15	835415
		16	835416
		18	835418
	Mechanical fitting for PEX pipe 3/4"E 835P	16x1.5	835561
		20x2	835601
	Mechanical fitting for multiSKIN pipe threaded, nickel plated 839	M22 -14x2	839514
		M22 -14x2	839516
		M22 -14x2	839418
		M22 -14x2	839420
		1/2"-16x2	1C2071001
	Compression fittings 835S	12	835712
		15	835715
	Compression fittings for copper 3/4E nickel plated 835E	12	835912
		14	835914
		15	835915
		16	8359161